

the
bhukkad
café

Name:

Class:

Section:

School:



भुक्कड

is

my

name

मकखन

is

my

prem



thebhukkadstory

humari kahaani

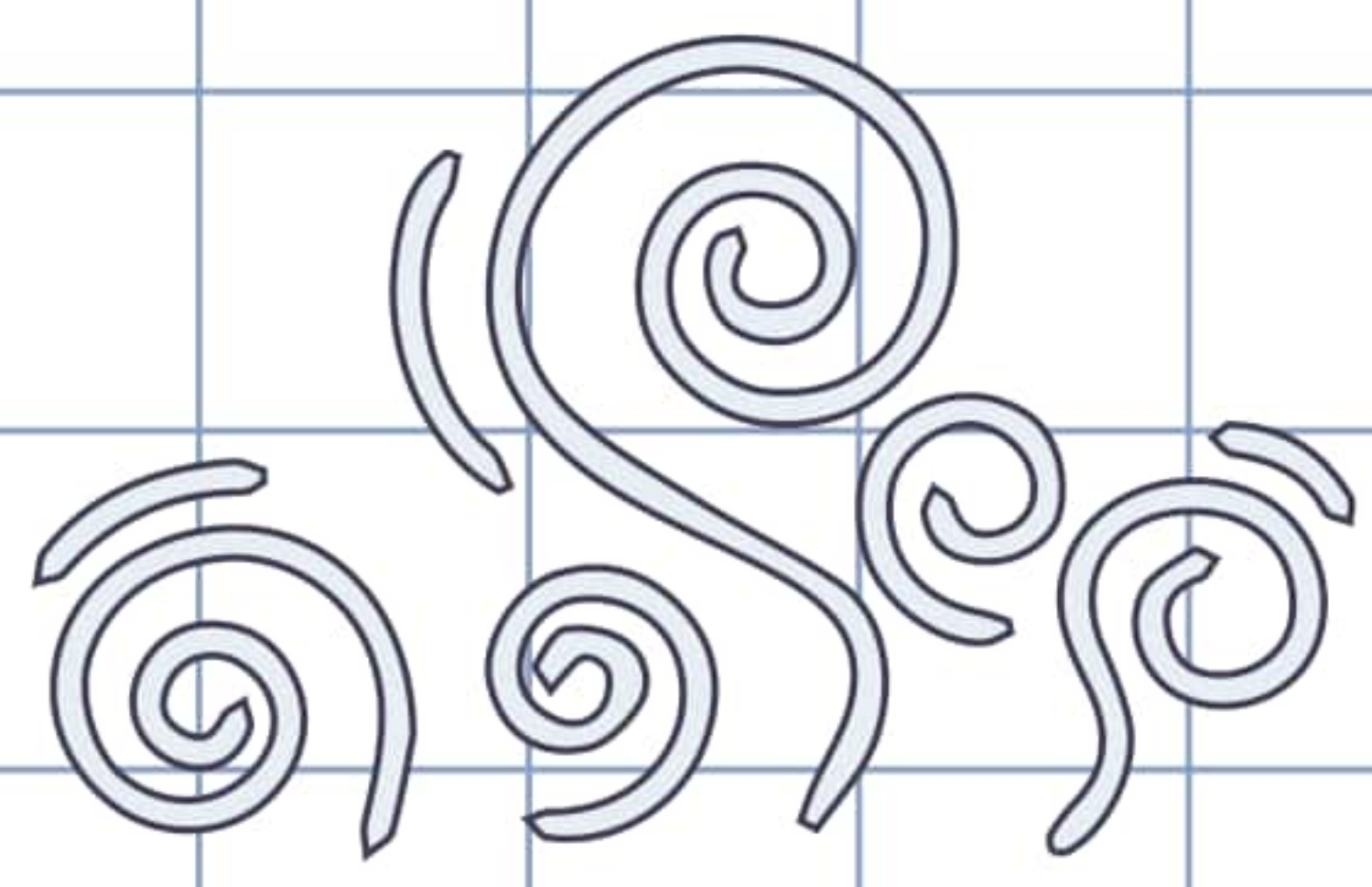

Ours is a simple story of friends that had left India.

The story began unfolding when the same friends began meeting often, and talking agitatedly and animatedly, of how much they missed eating a homely plate of Rajma Chawal. In their attempt to remember the gullys and nukkads of India, they began fantasizing about bhajiyas and vada pavs, that could have complemented their steaming cups of Chai.

When one friend reminisced fondly of the garlicky goodness of the roadside Chau-Mean & Chilli Chicken, they were all taken back on the topsy-turvy path of nostalgia, where the clouds lay low and the sun peaked through mountain tops. By the time, the friends finished their chutney sandwiches, they had already decided that a thick, foamy Gulkand Shake would have ended their night on a very rosy note.



On that night, The Bhukkad Cafe was born.

The Bhukkad Cafe is all about Food - Because, there's nothing that even comes close - Because, we love to eat a bit of everything, the sweet, the tangy and the savoury, and oh, don't even get to the fried.

Because, a Certified Bhukkad is always looking to satisfy the hunger of his soul.

The Bhukkad Cafe is all Desi - Because every Pind in our Des holds its unique cuisine and its rangeen streets that scream flavour.

The Bhukkad Cafe is all about Nostalgia - Because food memories make the best stories, and years later, we still remember our college canteen and that one hot chocolate that we had hurriedly sipped while studying for that board exam.

Our story is a simple one - made extraordinary because of a passion comparable to that of pani-puri, because of love that is laced with makkhan pavs & most importantly, because of a grit as crisp as a freshly fried samosa.

It is extraordinary, because, now, YOU are a part of it.

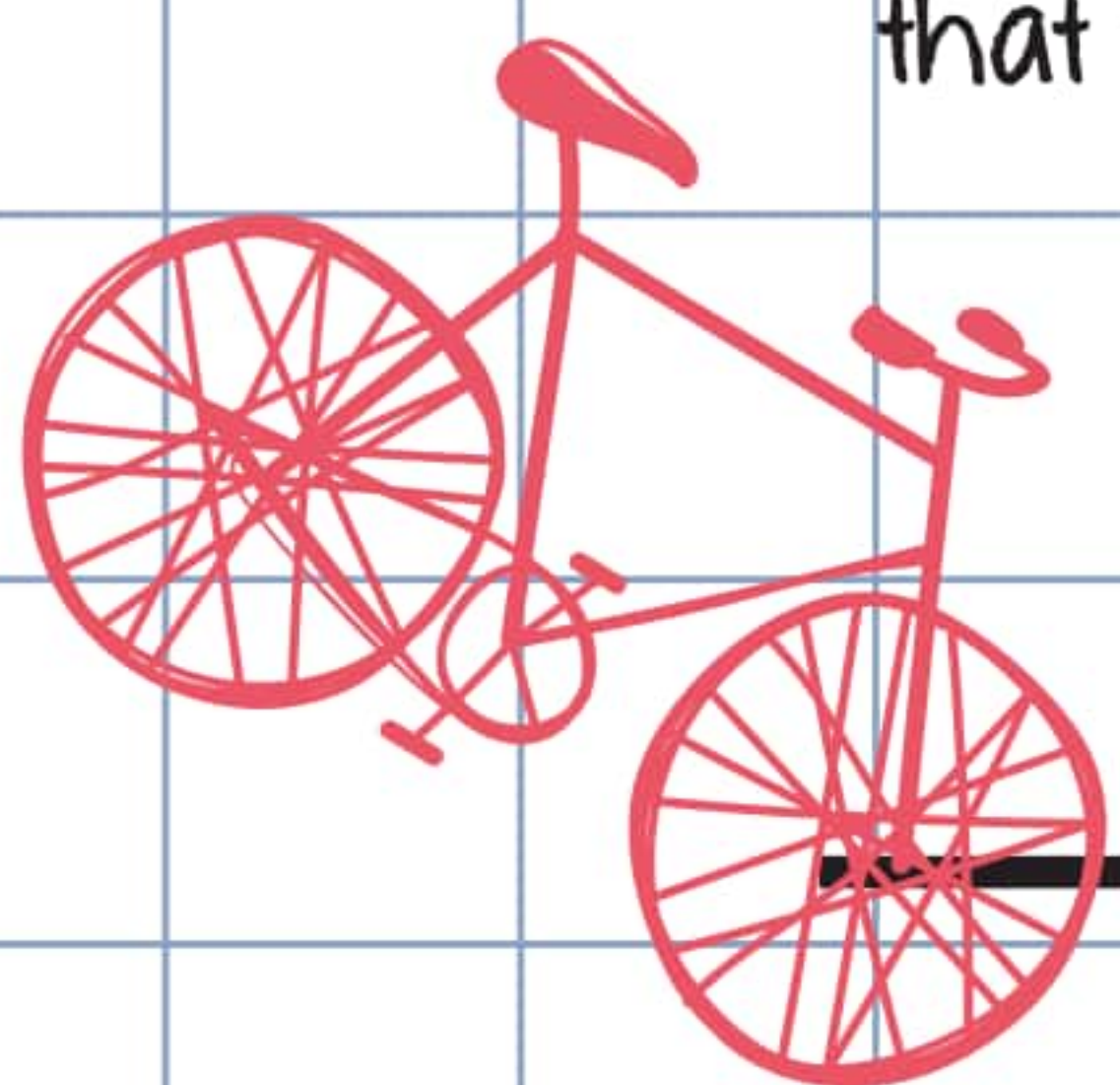

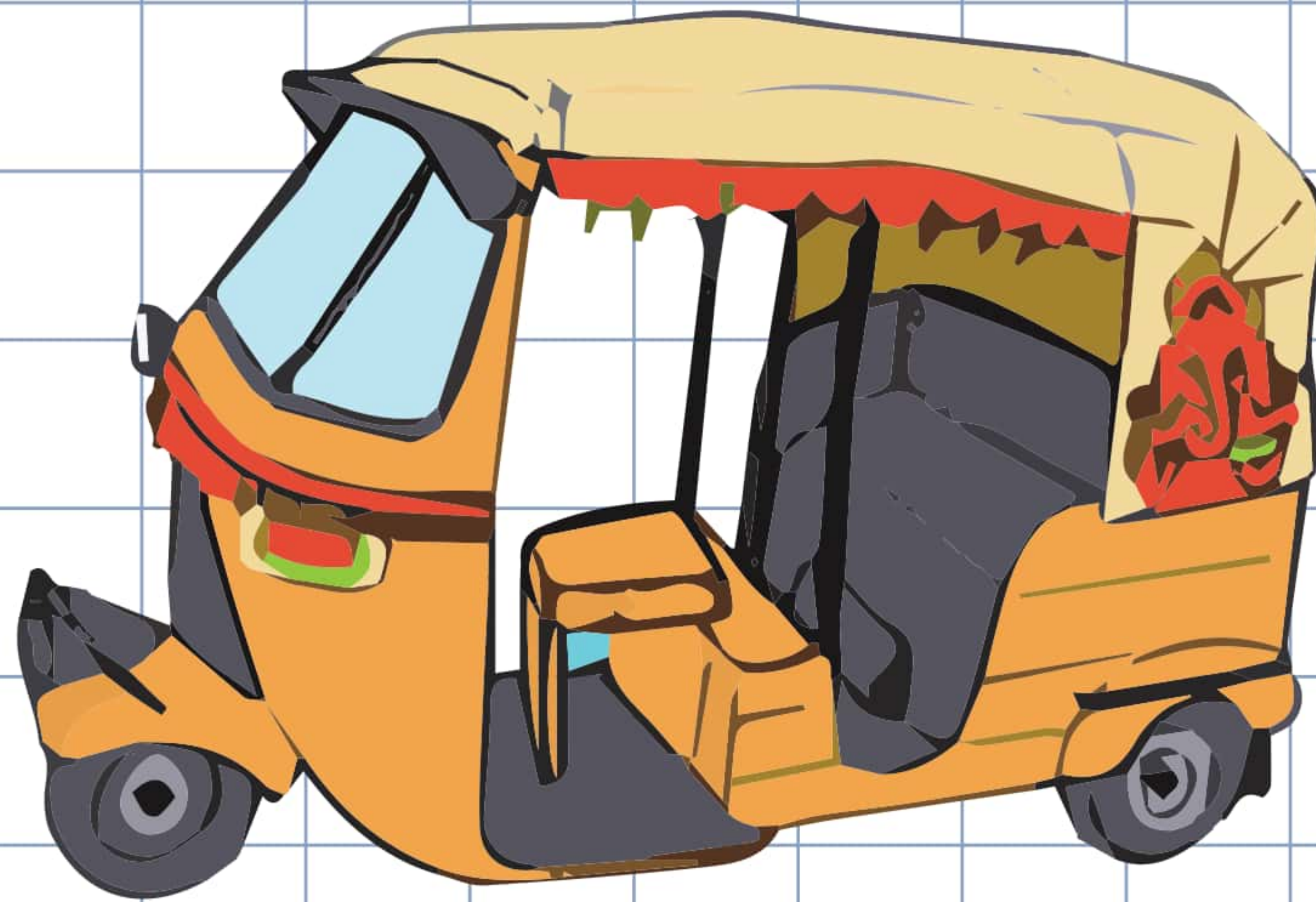

small bites

start off your Bhukkad journey
by ordering our small bites that
are big on flavour



thebhukkadmenu

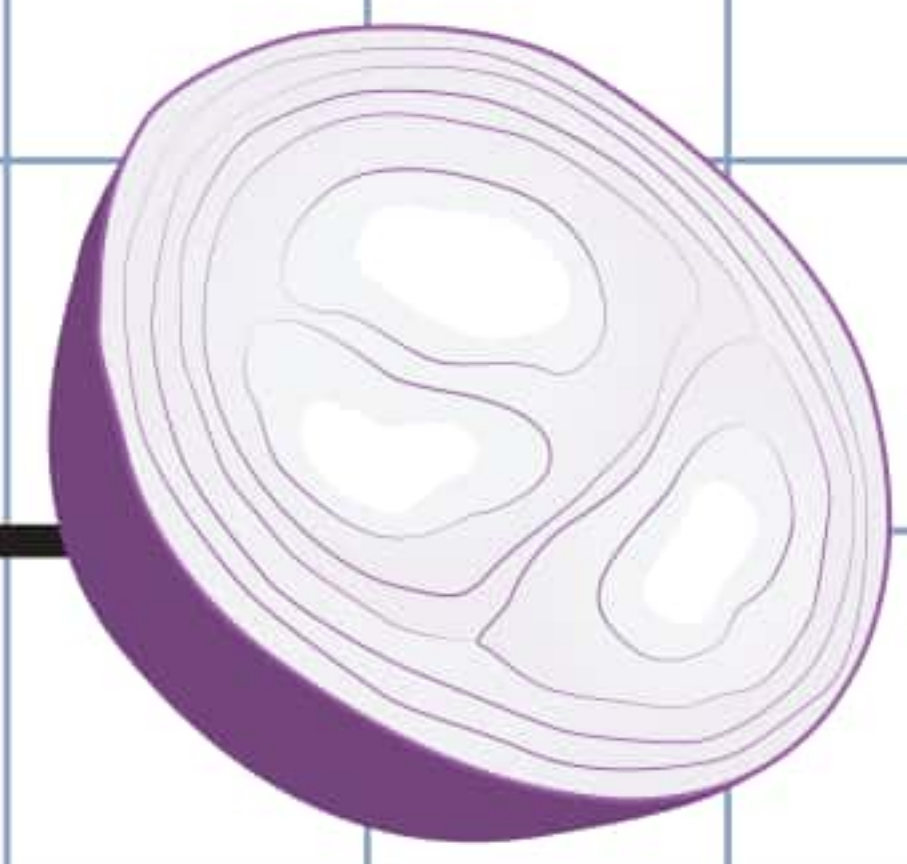

vada

pav

Classic
20

Cheese
Burst
26

Schezwan
26

kanda phool

Onion Rings. Coated with our secret masalas & besan. Fried to Perfection. A bite of our Kanda Bhajiya, and a sip of Chai. Transported home to Rainy Evenings.

26

100%
FRESH



Chicken
cheesy
bites

Paneer

Pan-fried and tossed in oregano, salsa sauce and melted mozzarella, stuffed inside sweet bakery roll bread.

34

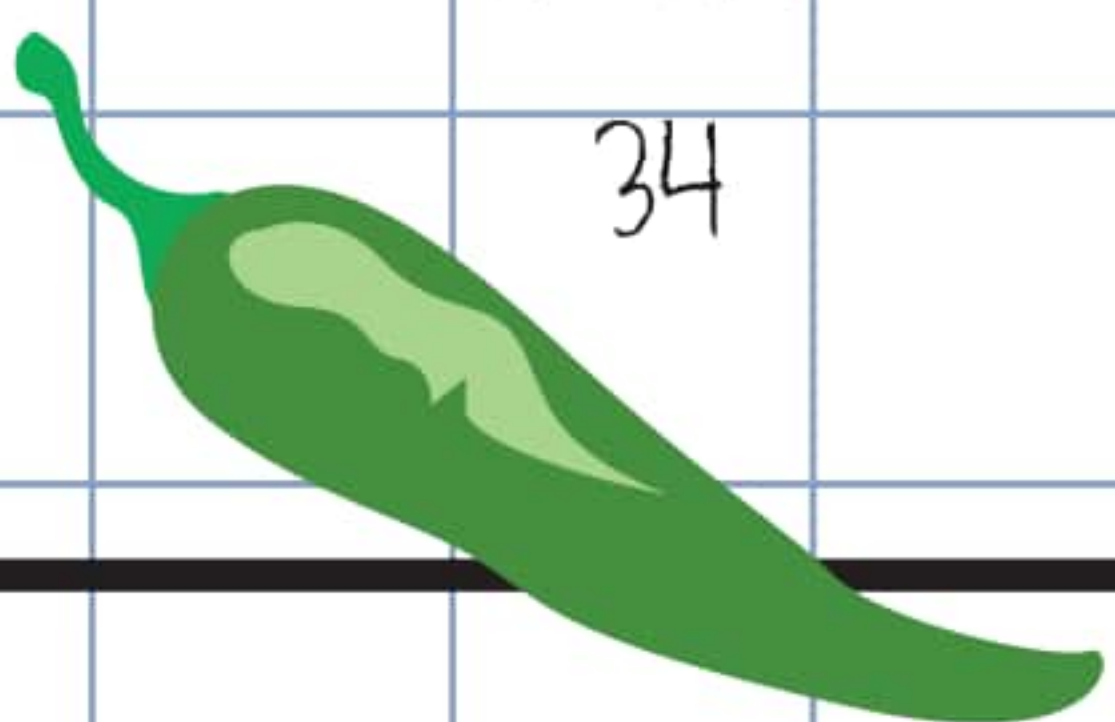

bread pakoda

An eclectic twist on the classic Bread Pakoda, this one will be a burst of surprise in the mouth, stuffed with paneer, capsicums & gooey cheese.

28



*made
with
love*

Nutella ←

Lotus ←

pizza on a puri

Best of both worlds - Italian Pizza Toppings meet Desi Sev Puri. Pick one up and crunch your way through culinary confusion

28

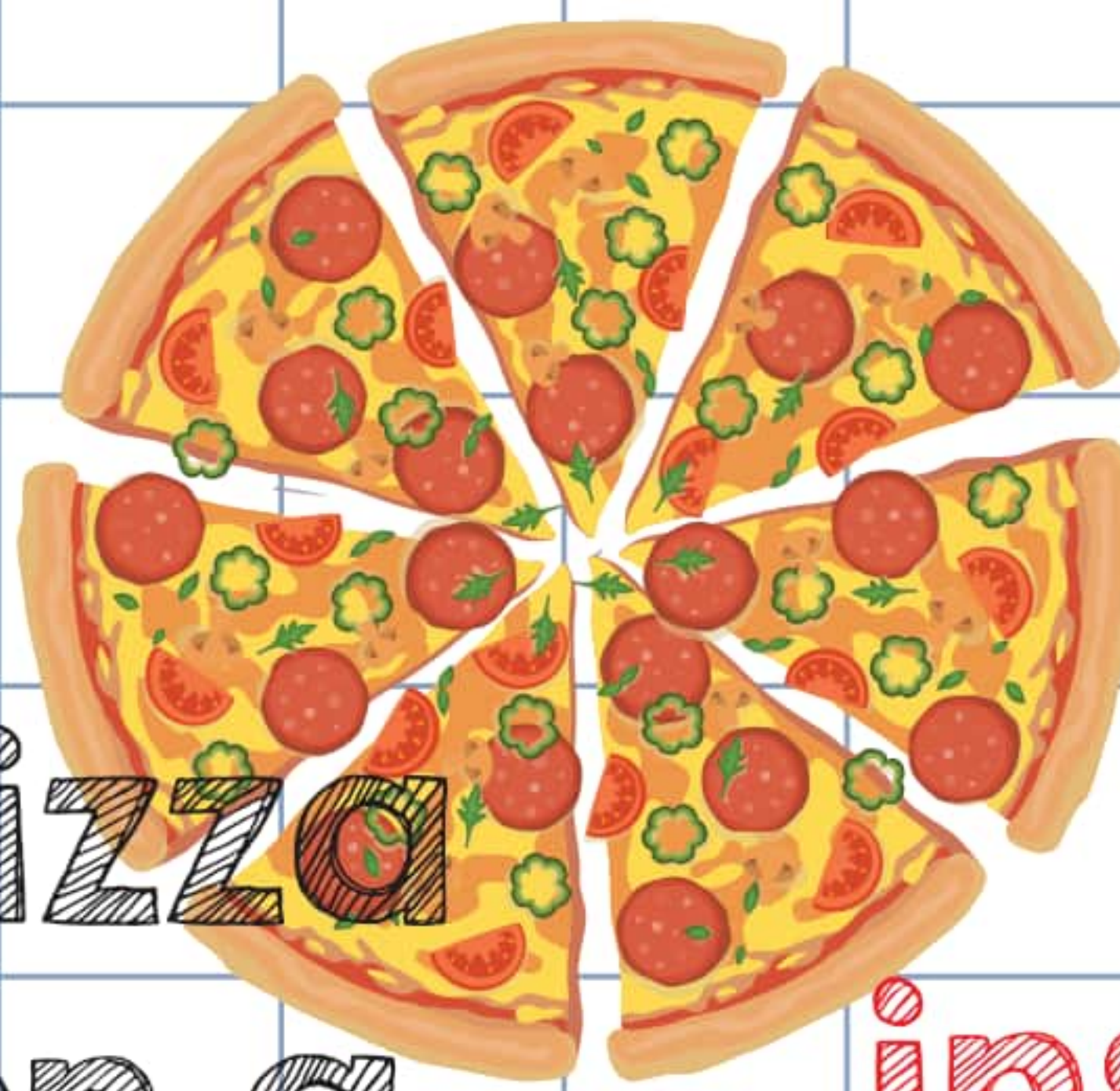

samosa

If someone offers you the corners of their samosa, marry them. No seriously, marry them NOW! - Add a Kettle of garam garam chai, and welcome to your honeymoon.

20



pav french toast

36



inside-out vada pav

Vada inside a pav inside a vada - confused? Order our Bhukkad Signature to be bamboozled!

28

the bhukkad menu

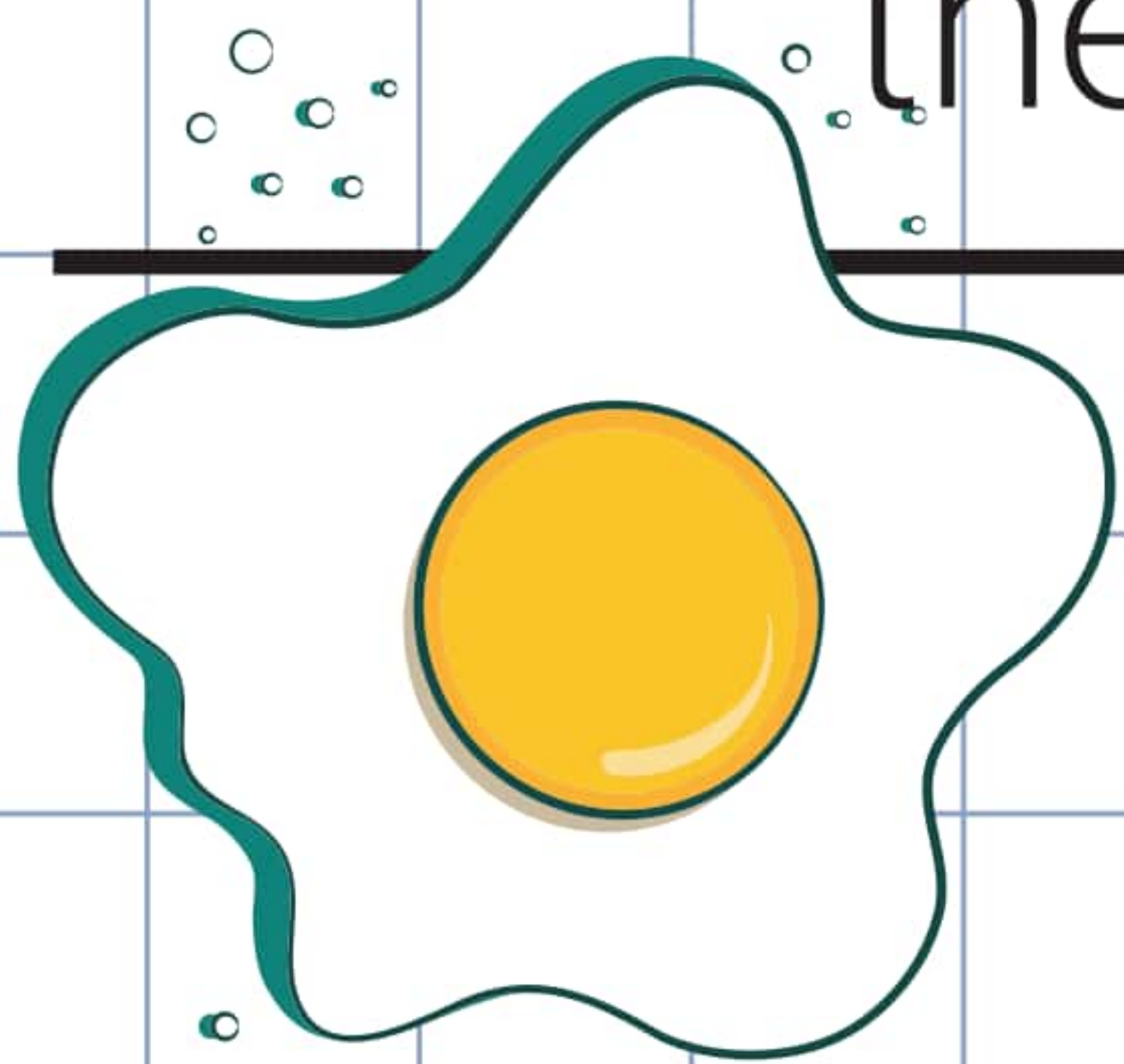

bread aamlate

Killer of Early Morning
Hunger Pangs, Regular at
Aam Aadmi's donas at
railway stations,
CEO of All Egg Dishes

28

bhurji pav

The classic Indian Anda
break-fast, with scrambled
eggs cooked in a
masaledar onion-tomato
mixture topped with green
chillies and coriander

30

aamlate pav

Two fluffy aamlates stuffed
between even fluffier pavs,
battered well and crisped up.
Add Cheese and Ketchup and
join the fluffy bandwagon

28



anda ghotala

Grated Boiled Eggs cooked
in a green dhaniya based
gravy, aplomb with
homemade masalas.

The ONLY ghotala you
need in your life.

34

Locally
grown

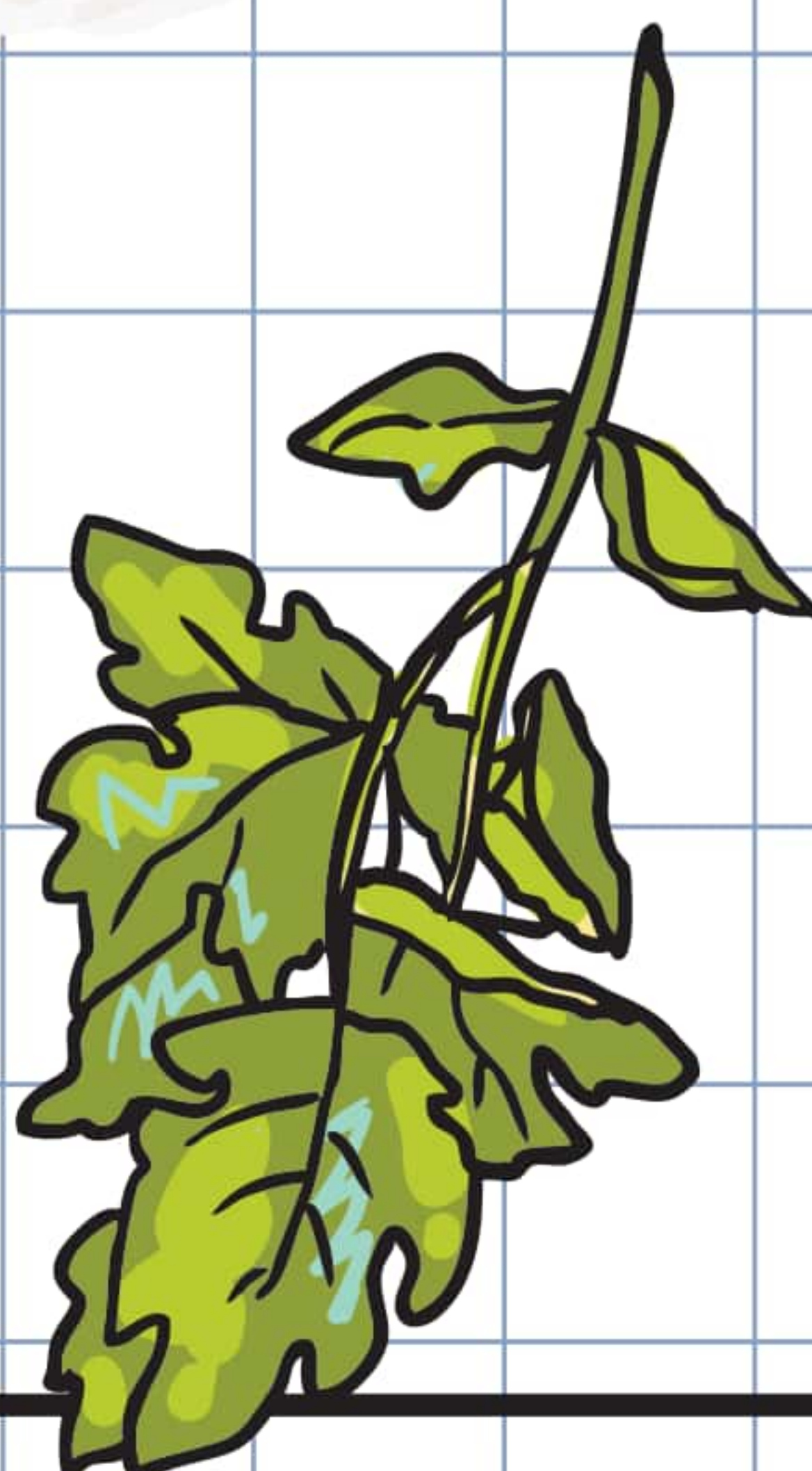
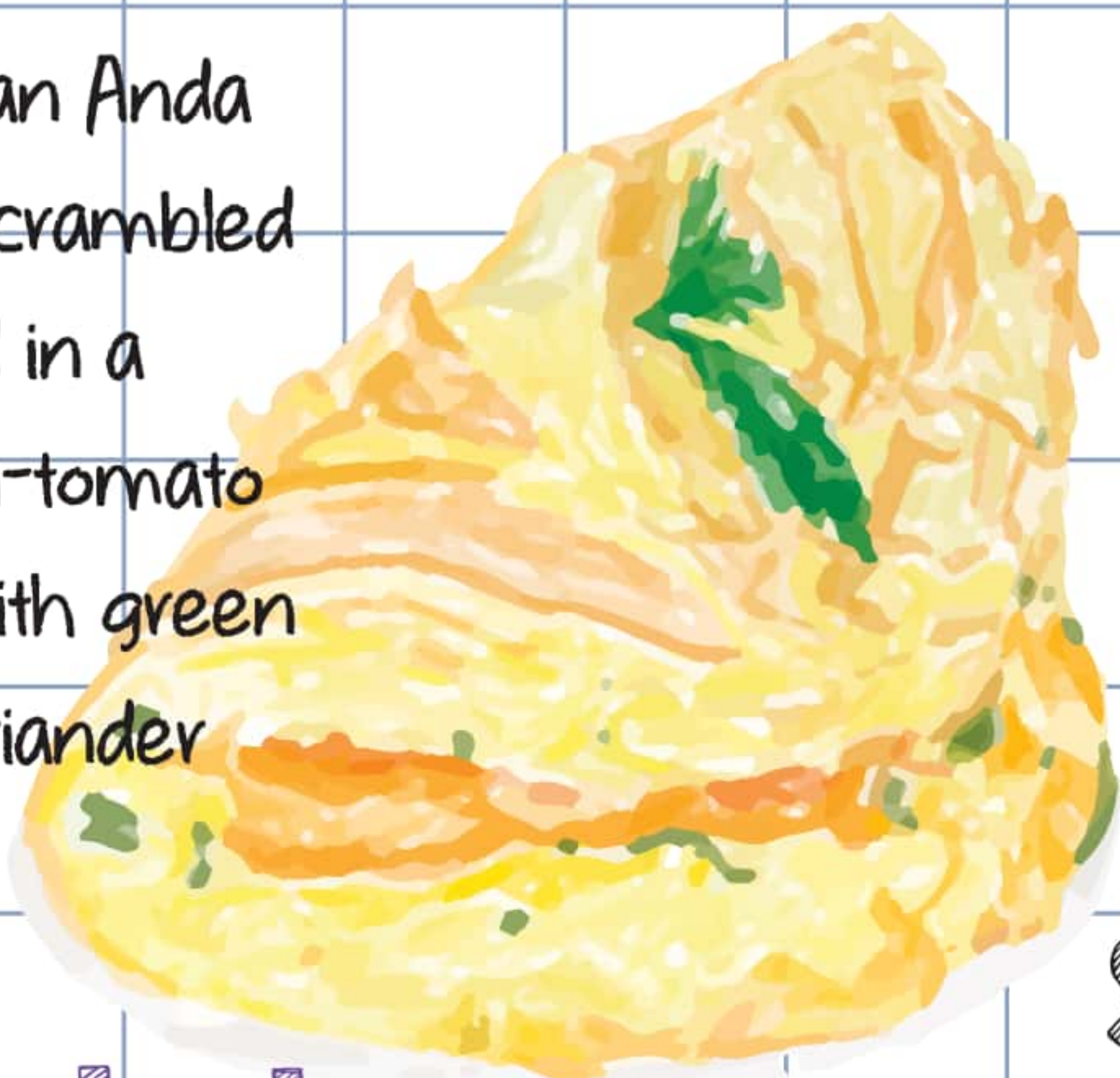

akuri pav

The Parsi Contribution to
Desi Street Food -
Scrambled Eggs cooked with
tomatoes and cream, usually
asking for second helpings.

32

desi shakshouka

Slow steamed Sunny Side
Ups swimming on a bed
of a rich red gravy.
Best eaten hot with Pav.

34



seekh kebab aamlate

Latest in the desi street
food scene, eat it when you
are really hungry - A fluffy
masala omelette topped with
juicy seekh Kebabs leaving
you going for bites after
bites.

34





the bhukkad menu

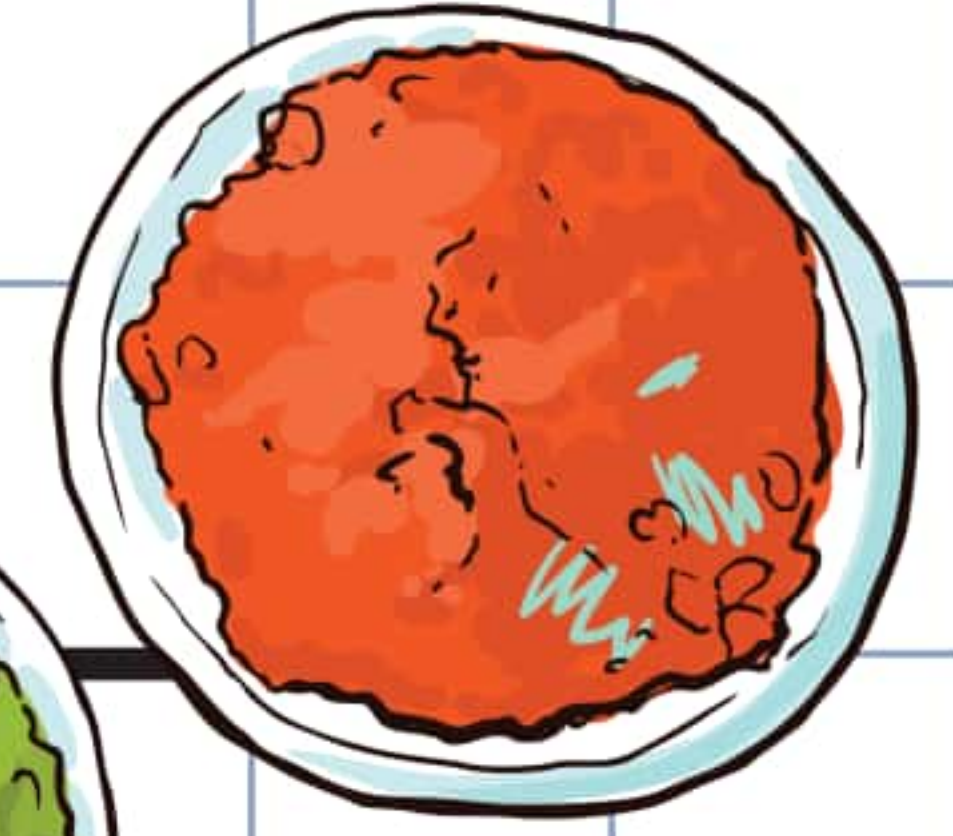

dil dhadakne do

Dil loves Chocolate
Dil loves Nutella, let your Dil do Dhak Dhak & eat this gourmet sandwich with nutella oozing from buttery toasted bread.

32

mithibai grill sandwich

Fondest Food Memory of MumbaiKars - Stand on the sidelines of Mithibai College, and watch your Grilled Sandwich come to life - Raise hands if you ever asked - Bhaiya, extra cheese

denal!
32

sev puri sandwich

One of its Kind - freshly prepared sev puris with teekhi & meethi chutneys, sandwiched between grilled toasts.

32

oreo grilled cheese

36



aloo cheese toast

Street style Masala Aloo, onion and cheese sandwich toasted to tango!

28

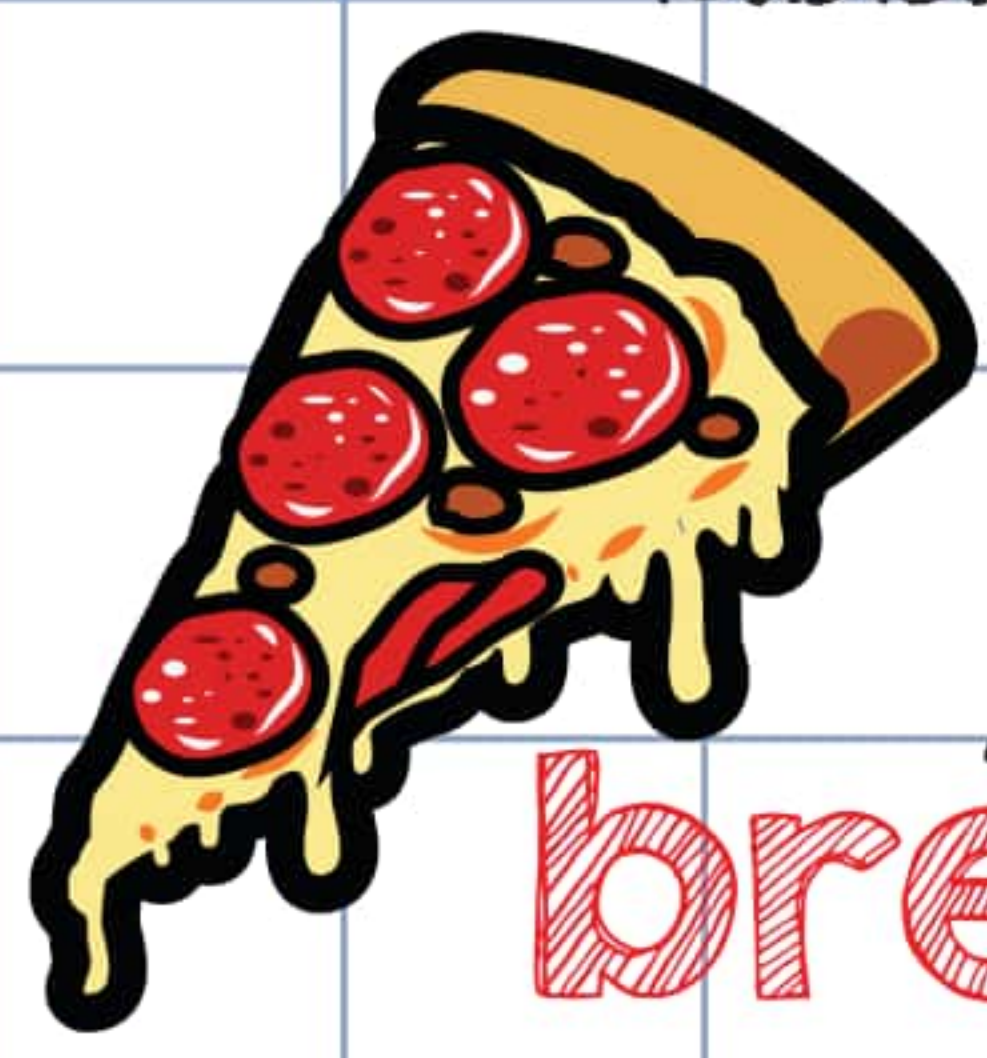

bread pizza

Veg. Chicken +4

34

chicken afghani sandwich

Tandoori spiced chicken with makhni mayo induced flavours sandwiched to satisfaction.

38



chilli cheese toast

Baked until the obnoxious amount of cheese turns golden, topped with chilli flakes, oregano & a long session of gupshup.

28



chicken jungle sandwich

Crazy concoction of boiled chicken, onions, mayo & green chutney, sandwiched & grilled

until crisp.
38

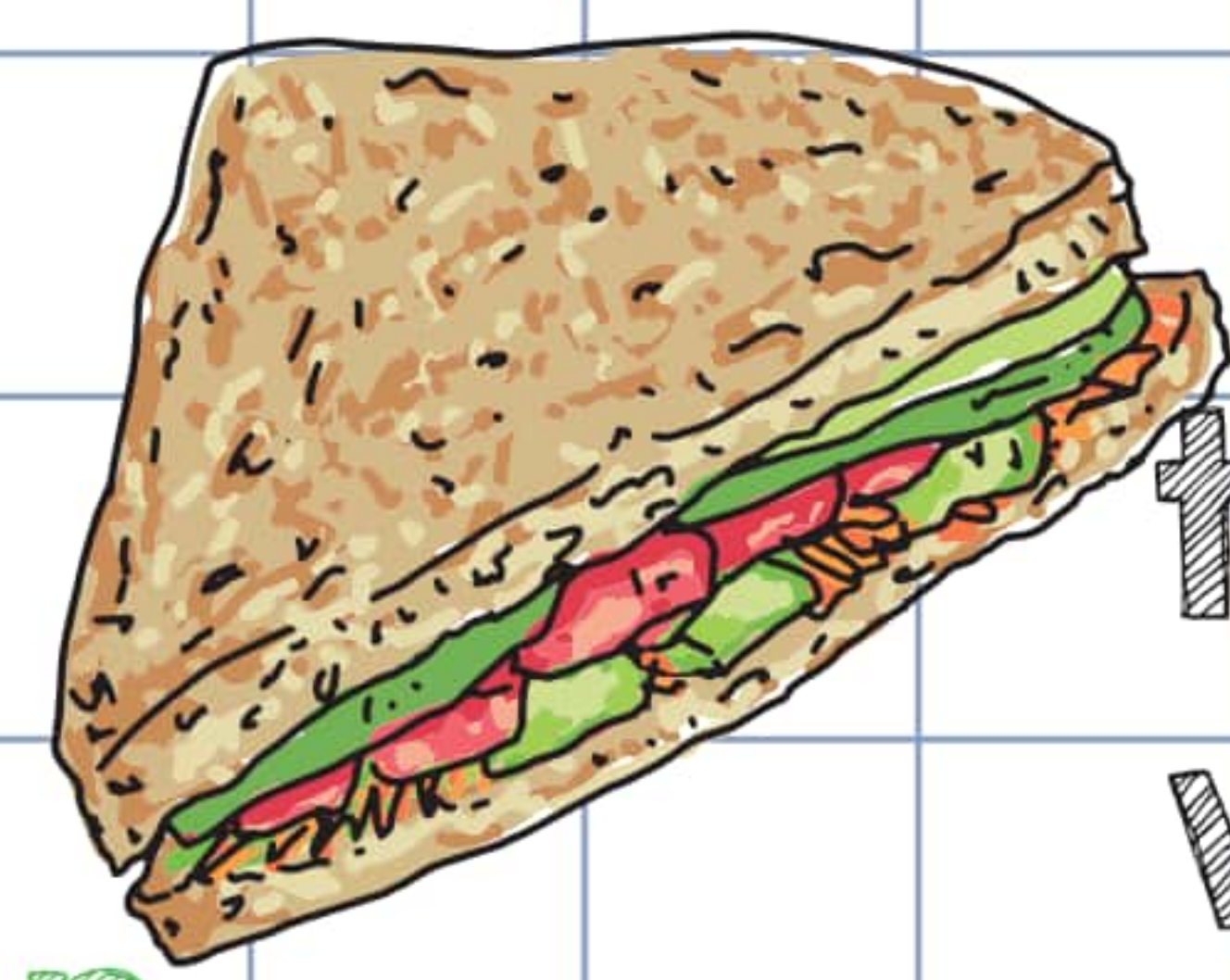

thele wala sandwich

Filled with cucumbers, potatoes, butter & pepper, will take you down memory lane.

28

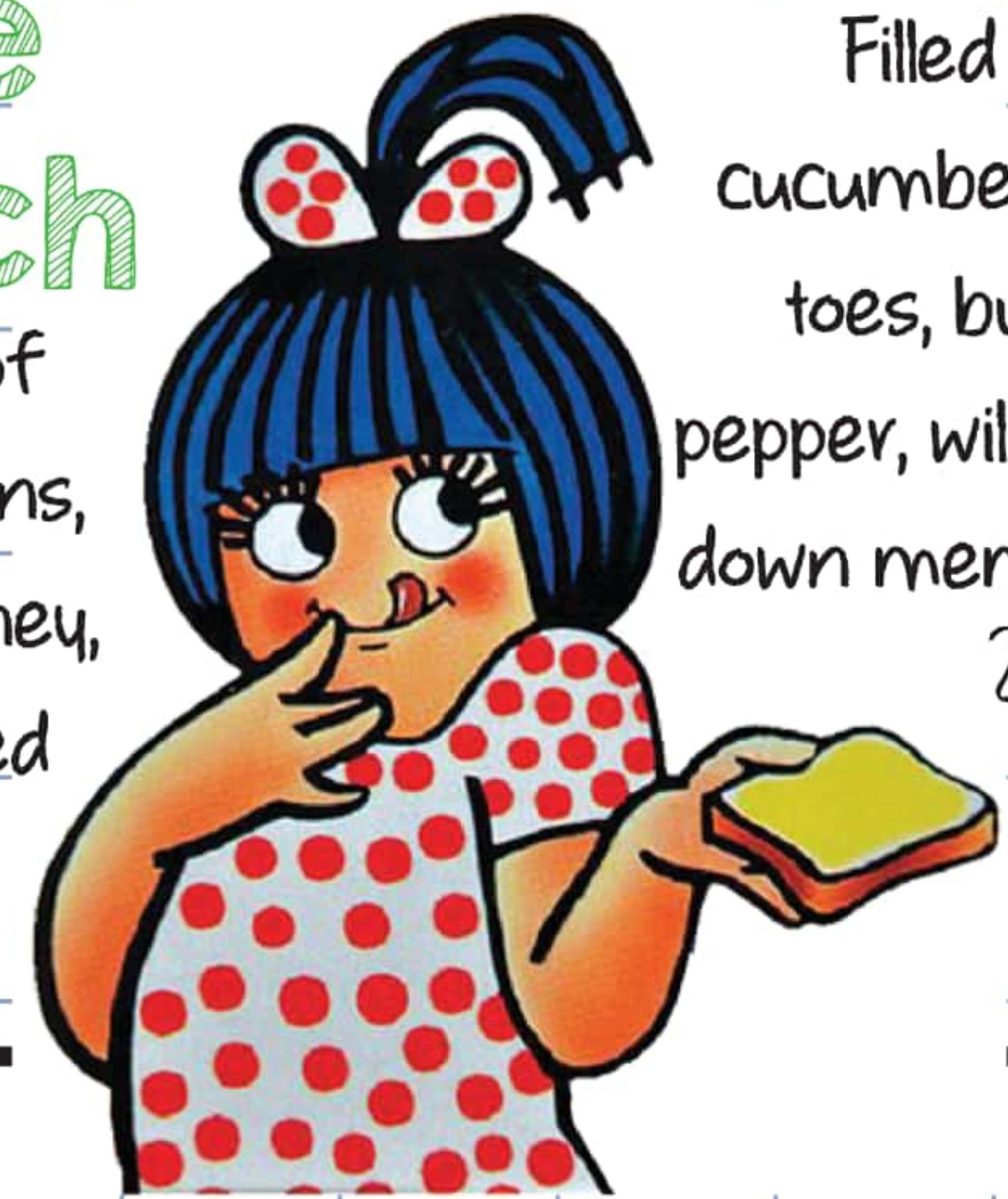

the bhukkad menu

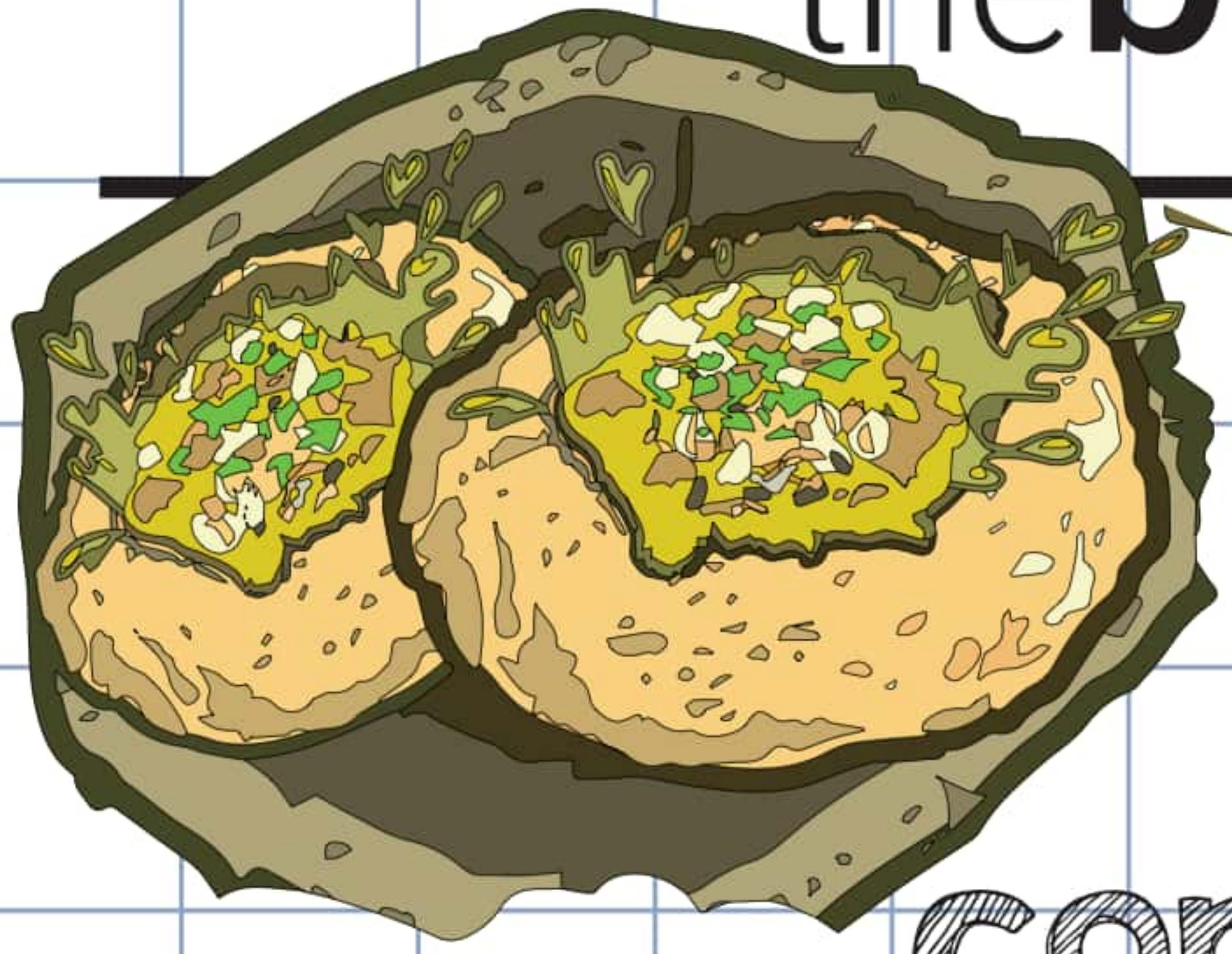

rangeela
pani puri

28

cheese
burst
pani puri

38



sev
puri

26

corn
chaat

24



paapi
papdi

32

chaat

ok

bombaiya
bhel

26

ching
chong
bhel

28

dahi
batata
puri

28

please

jhal
muri

26

chole
samosa

32

NEW
chips
ki
chaat

28

palak
patta
chaat

32

chandni
chowk
tikki

32

mast
masala
papad

16

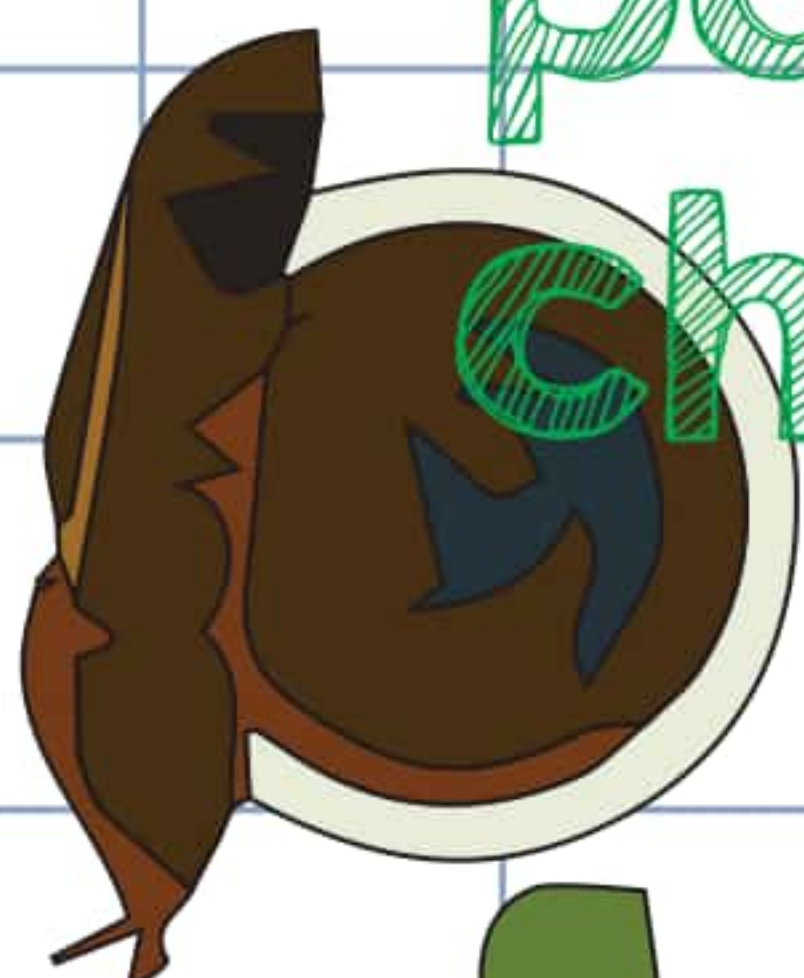

chaat
platter

48

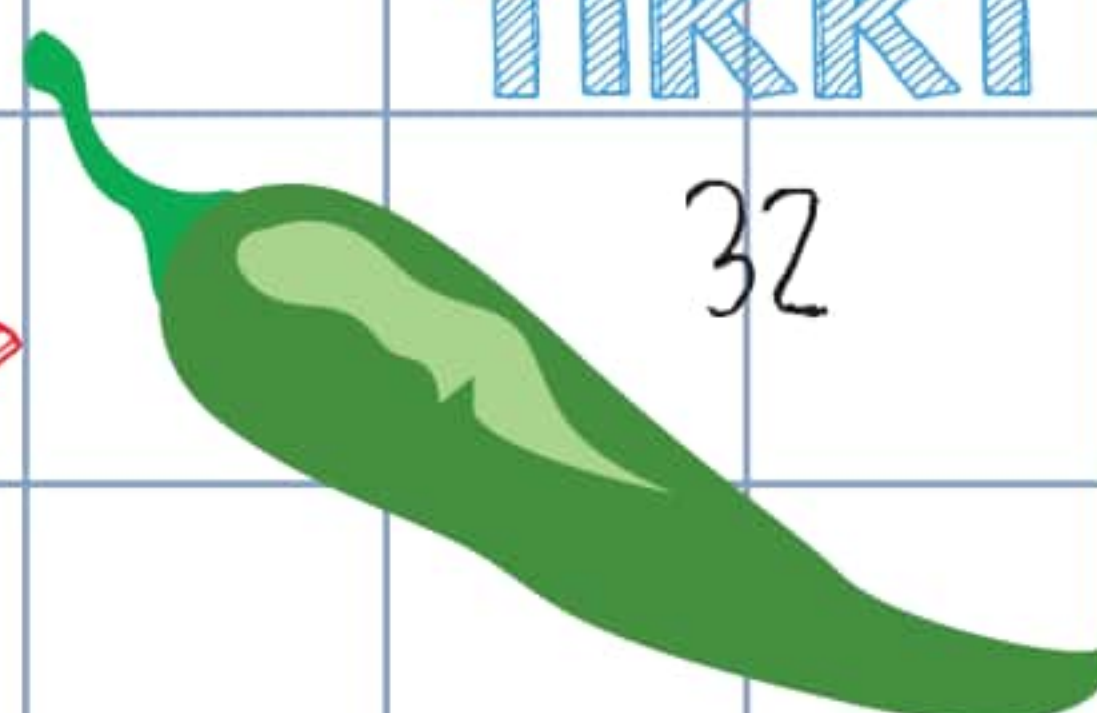
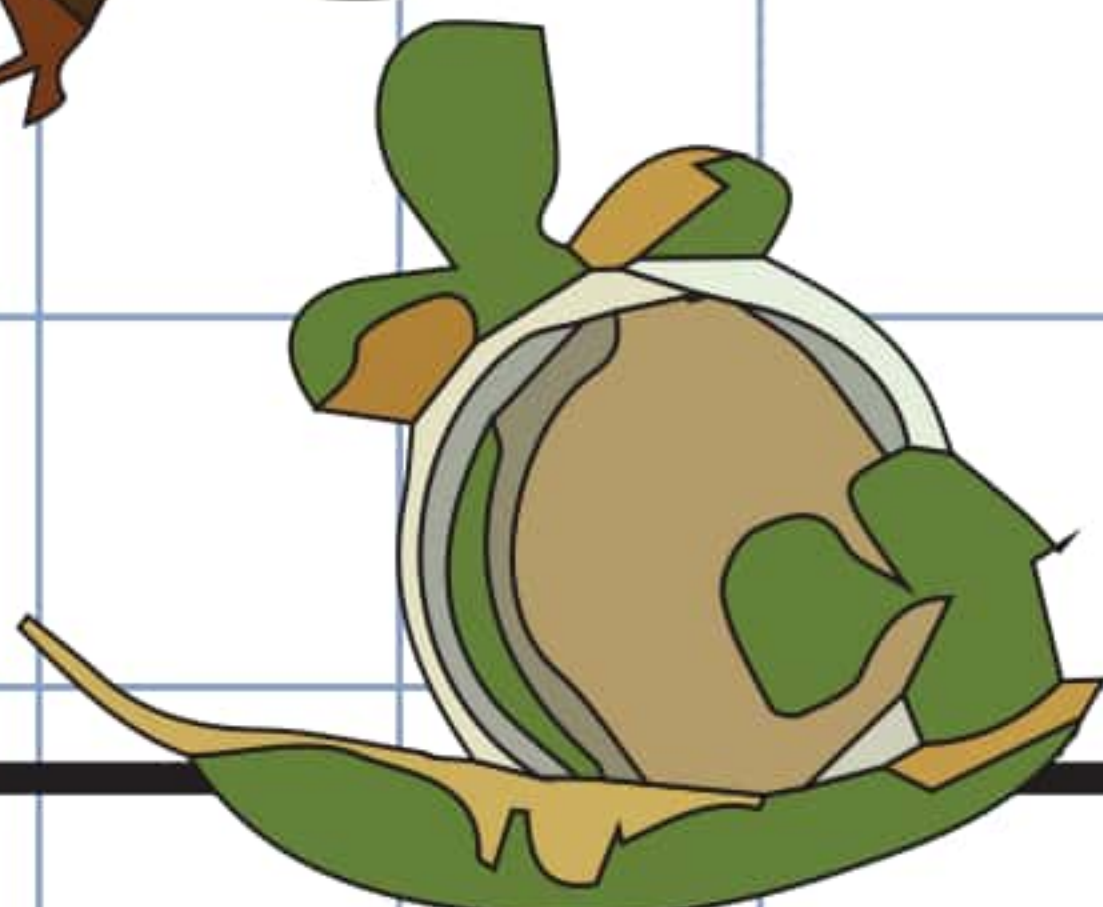



big bites

continue your experience by
going all out on the big bites
- remember, a true Bhukkad
can't eat just one



the bhukkad menu



kolkata chilli chicken

Juicy pieces of boneless chicken fried in desi chinese sauces - hot, crispy, tender and eaten extensively by the HANGLAS of Kolkata
38

chau mean

Kolkata's Obhimaan (Pride of Kolkata Street Food Scene) - Garlicky & Spicy, tossed in spicy sauces

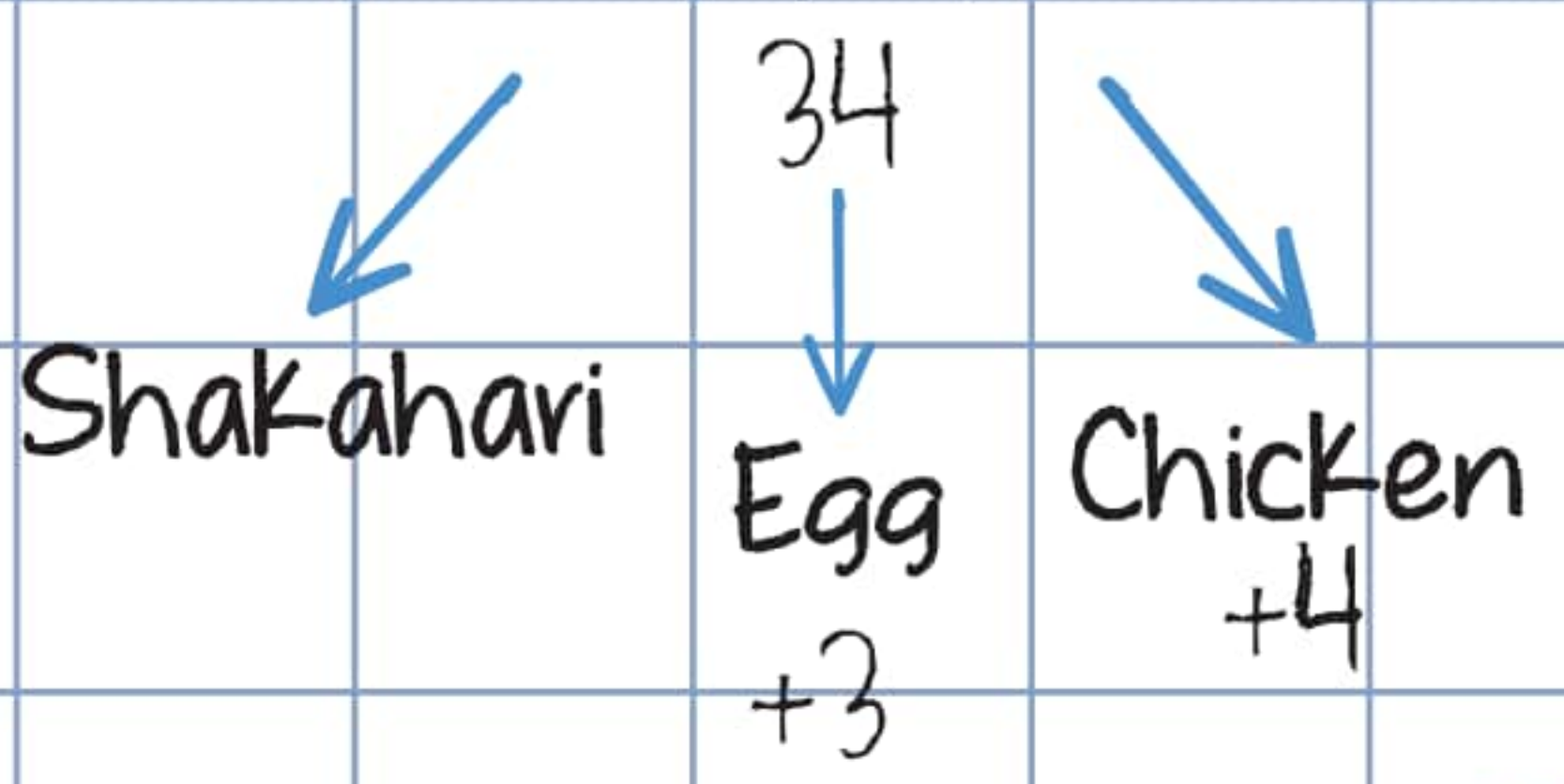

NEW momo mania

Escalating from hilly streets of North East India to reaching mainstream media attention - momo is on its way to stardom, now co-starring with Makhni, Chinese & White Sauce.
32

mera wala maggi

2pm or 2am - Maggi has always been there for us - Through our hostel days & our break-ups - Maggi is BFF, Maggi is Bae
24

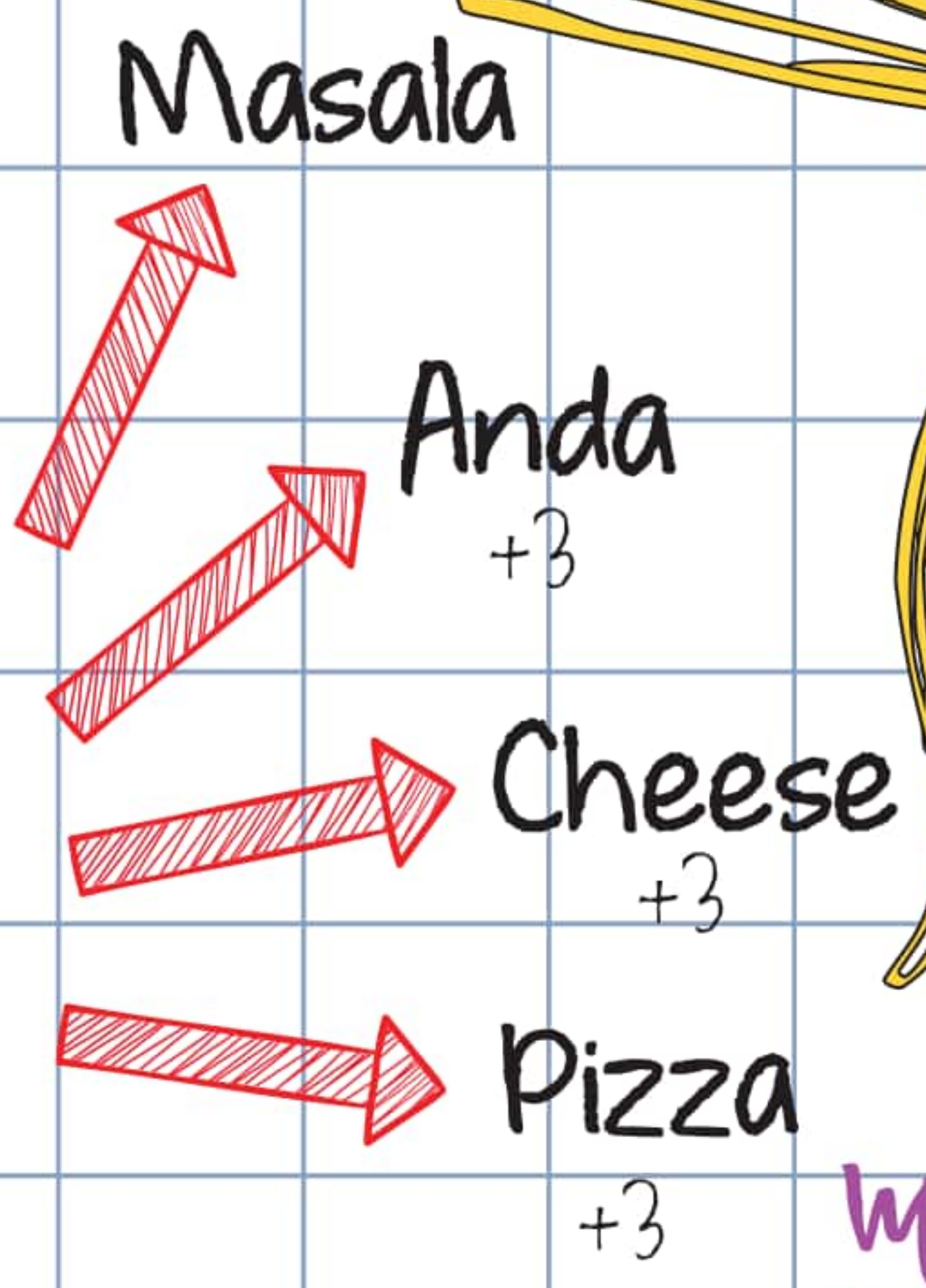

made with love

100% FRESH chilli chicken pav

Our favourite Chilli Chicken served with makhhan pavs and a side of ching chong bhel. Part of our Pav Wow Series.
42

crispy chilli paneer

Fresh cubes of malai paneer marinated in Chinese 5 spices and fried crisp with onions, capsicums and road side sauces.
38

fried rice

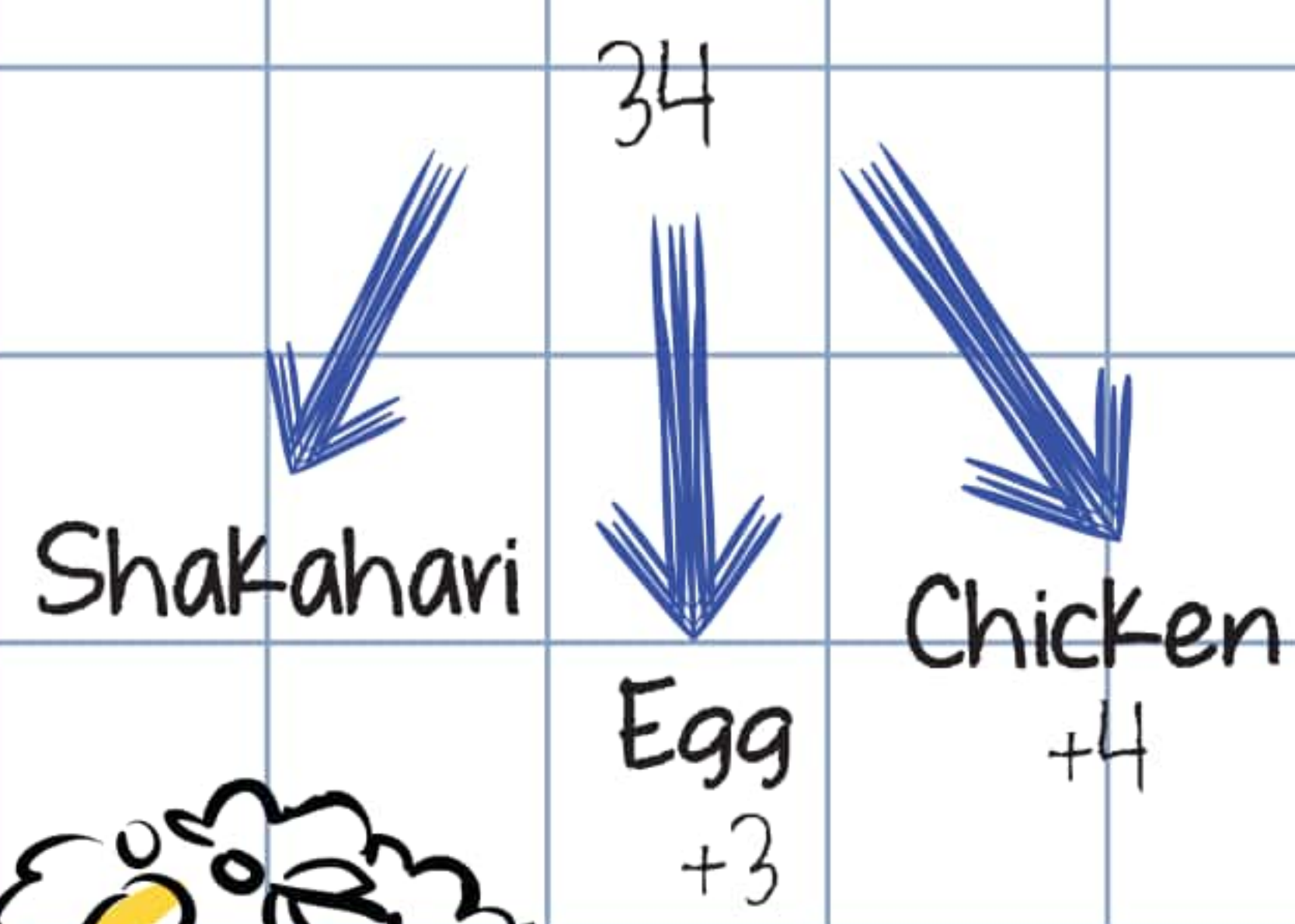

NEW triple schezwan rice

Classic mix of spicy schezwan rice & hakka noodles spiced to take you back to the gullys of Aamchi Mumbai
38

the bhukkad menu

100% FRESH

keema pav

An Irani Favourite - Made with soft, succulent mutton Keema, spiced with whole garam masalas, bubbling with anticipation from the first bite

42



tu cheese badi hai mast

Freshly made fries lathered with our cheesiest signature sauce and topped with masalas and mayo

28

fries

Joey never shares his fries.

Joey is smart.

Joey is a Bhukkad. Be Like Joey

- Order more than one so noone steals yours!

24

Pizza +3

Honey Chilli

Chilli Chicken +4

Paneer Tikka +4



bhukkad burger

Aloo Tikki

34

Chicken Makhni

38

Farm fresh



chowpatty wali pav bhaji

Marine Drive, Queen's Necklace, A Walk Down Chowpatty & Soaking into a big plate of Pav Bhaji - Jisme always, Bhaji jitna Butter.

38

jhumo nacho

A sure-shot Party Starter - Jhumo Nacho is flamboyant in flavour - a bed of nachos topped with options galore.

34

Maggi

Classic Cheesy

Pav Bhaji

Aloo Cheese

Paneer

Egg

Chicken

Keema

bombay frankie

32

made with love

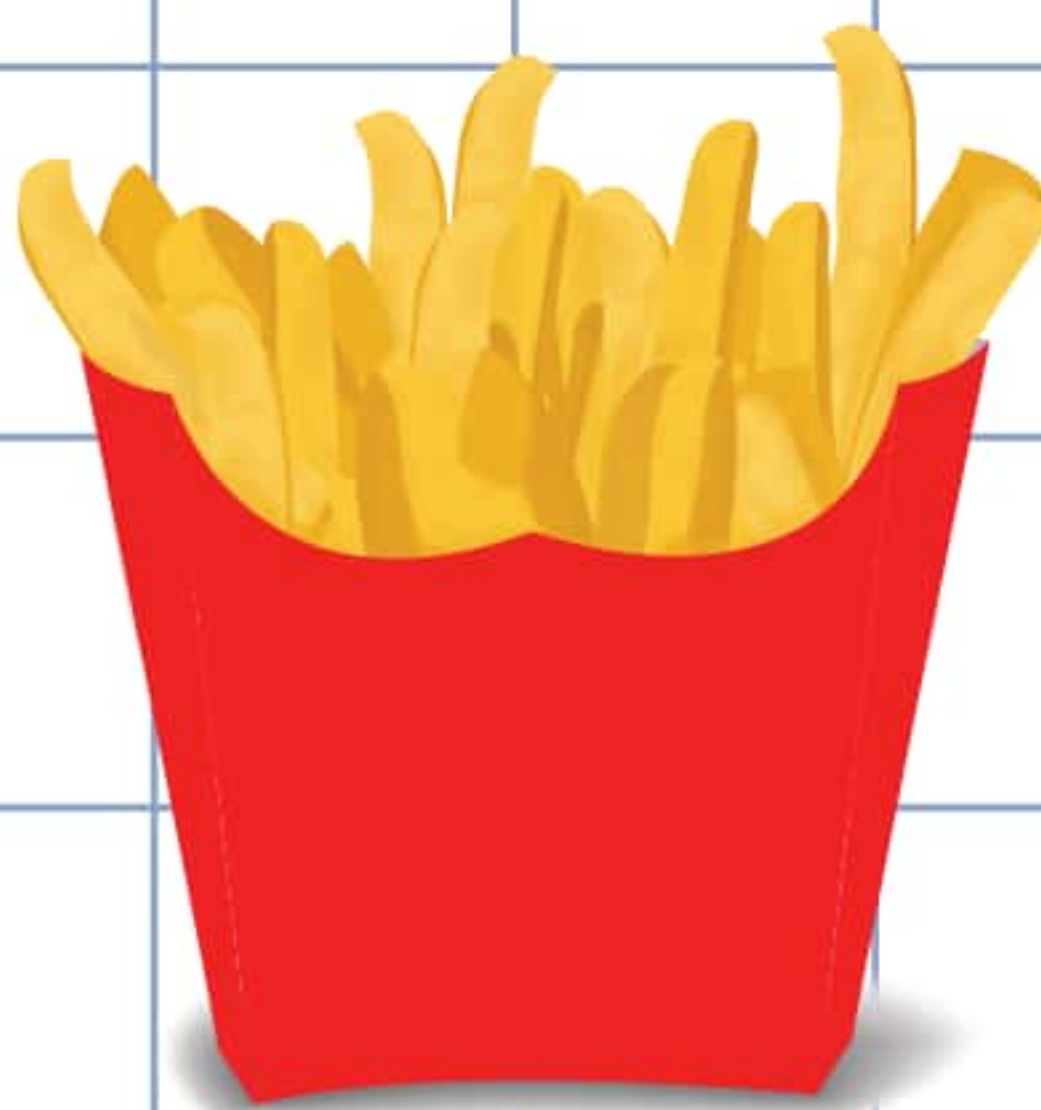

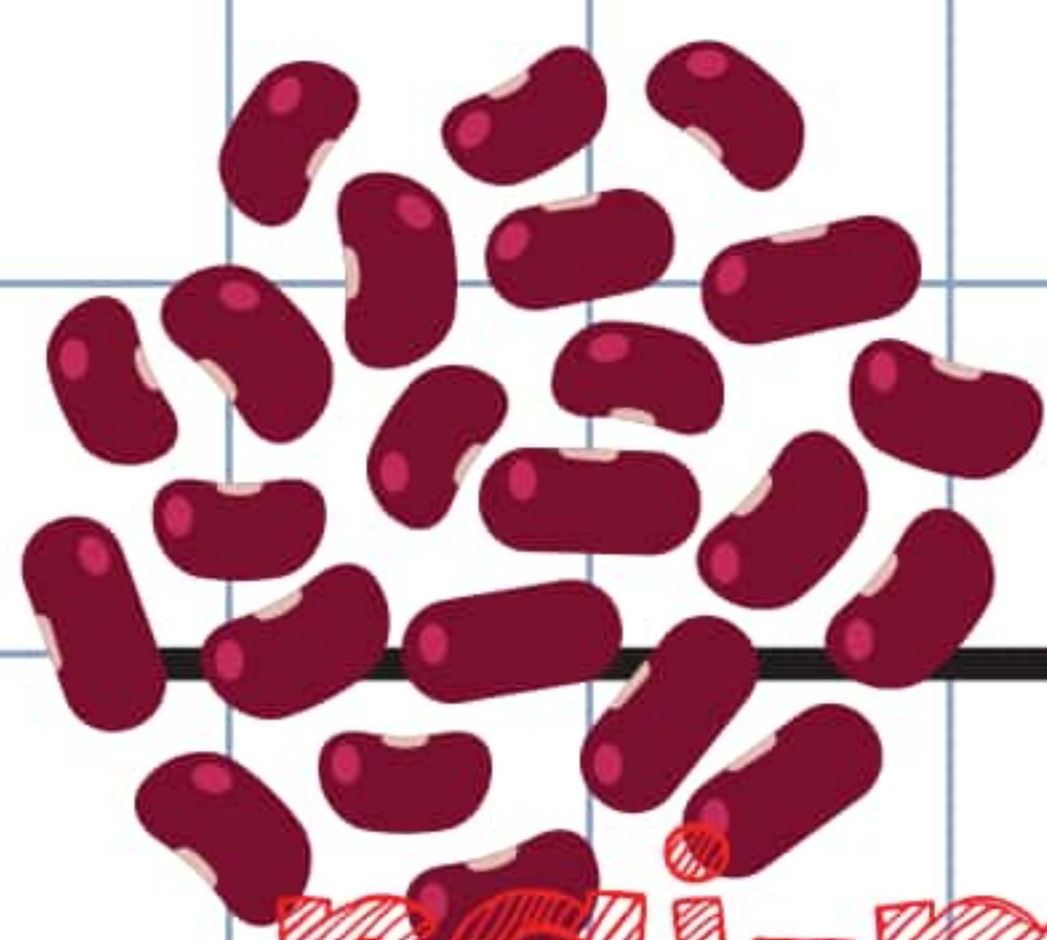

thebhukkadmenu



raj-maa chawal

We expats have left our homes far behind, but we still crave that ghar Ka Khana - Raj-Maa Chawal is Mummy Ka Pyaar

38

pull-out pav

Stuffed with paneer, oodles of mozzarella, and brushed herby garlicky butter, this one takes the award the moment it is out of the oven.

38

pakwan dal cups

Chana Dal with spicy tadka, layered with imli & green chutneys and oniones - Served with freshly fried crispy bread. Smack & Lick!

38

dal makhani shots

Shots of creamy Dal Makhni served with crisp bread - Enough to satisfy your cravings any time of the day - Also, a Bhukkad doesn't care about time.

A Bhukkad only Eats.

38



bhukkad ka kukkad

Drama meets Taste
Dahi meets Garam Masala
Ginger meets Garlic
Bhukkad meets Kukkad

48

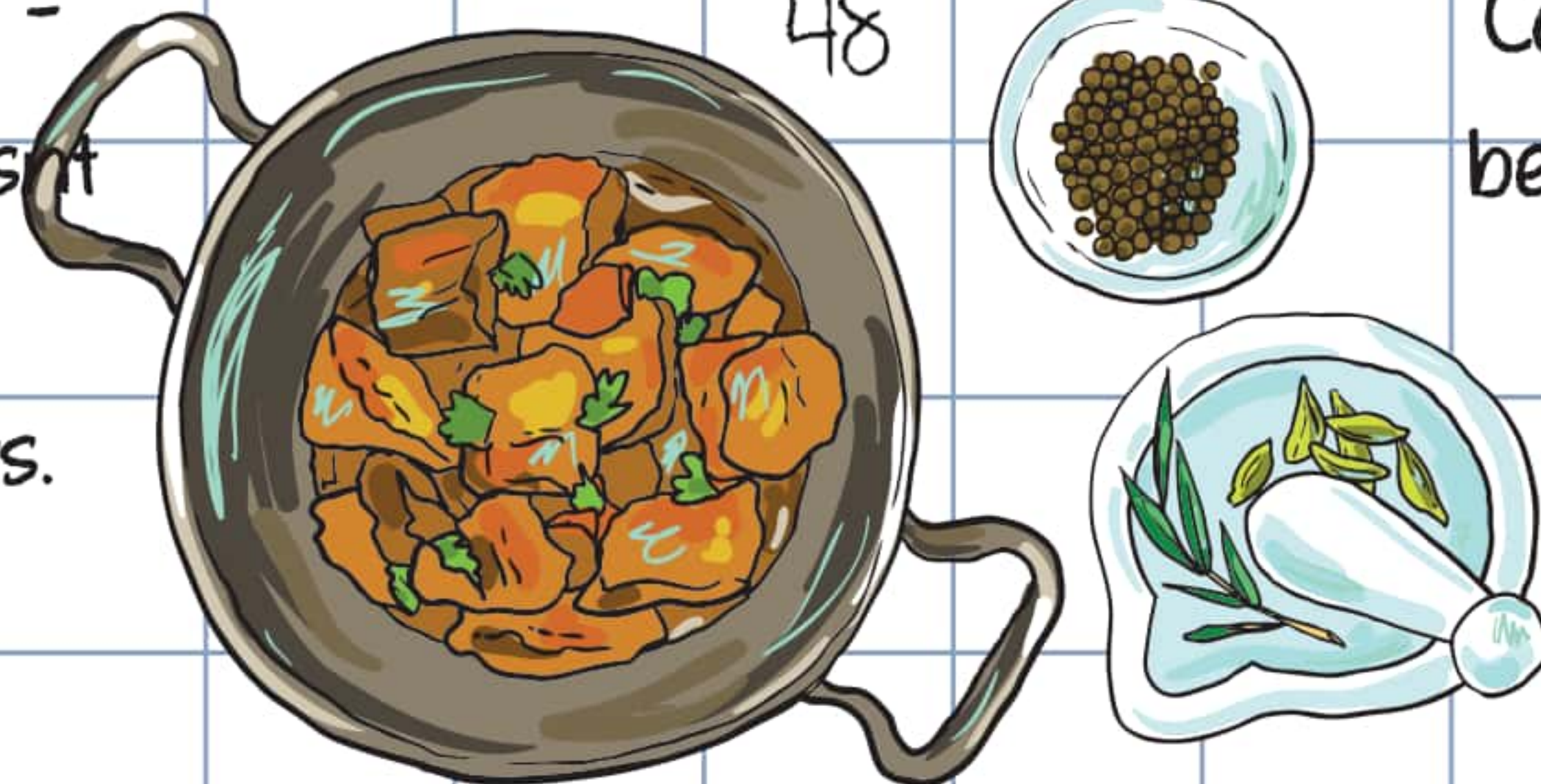

mac n tikka

The mildness of a creamy white sauce pasta loaded with cheese or the heat of red tikka sauce pasta? - Can't Decide? You're in luck, because Mac n Tikka to the rescue.

42

masala khichdi

Khichdi Ke Chaar Yaar - Ghee, Dahi, Papad & Achaar - Eat Khichdi only when all 4 yaars come together!

34



railway curry

Veg
34

Non-Veg
38

chole bhature

Pindi Chhole, cooked until soft, simmered in a gravy of onions & tomatoes, poured over fluffy bhaturas - You might want to go to sleep after

this.
36

NEW

thebhukkadmenu



mathura ke dubki wale aloo puri

Mathura-style aloo dunked in spicy gravy flavoured with hing, jeera & green chillies

Served with piping hot and fluffy puris

36

100% FRESH

dilli ke mashoor chole chawal

A mouth-watering plate of chawal topped with pickled onions + green chutney and spicy chole

Served with papad

38



ande ka funda curry

Two Boiled Eggs slow cooked in a simmering spicy onion & tomato gravy

Not for Mamooli

bandas

38

big bhukkad thali

(12 noon - 3 pm)

Made only for the hungriest souls -

Chaat + Chole + Rajma +

Rice + Paratha +

Sabzi or Chicken Curry

Don't forget

Dahi + Papad + Achaar

44

lasooni dal tadka

Garlicky, Buttery, Spicy & Smoky-flavoured dal topped with green coriander

Vegetarians Ka mai-baap

36



martaban kukkad

Our secret Chicken recipe made with lots of ginger, garlic, onions & tomatoes - slow cooked & tangy

46



sides

Rice 15

Lachcha Paratha 8

Bhatura 10

Puri 6

Pav 4





thebhukkadmenu

bhukkad butter kukkad

Classic Butter Chicken meets flavourful, luscious & creamy buttery gravy - no one can eat just one!

Best paired with Paratha or Rice

42



100% FRESH bhukkad butter paneer

Fresh Malai Paneer swimming in a pool of buttery, thick & lip-smacking gravy of slow

cooked tomatoes

Best paired with Paratha or Rice

40



butter chicken sandwich

Our Classic Butter Kukkad turned into a wholesome sandwich oozing with cheese, chutney and chicken

38

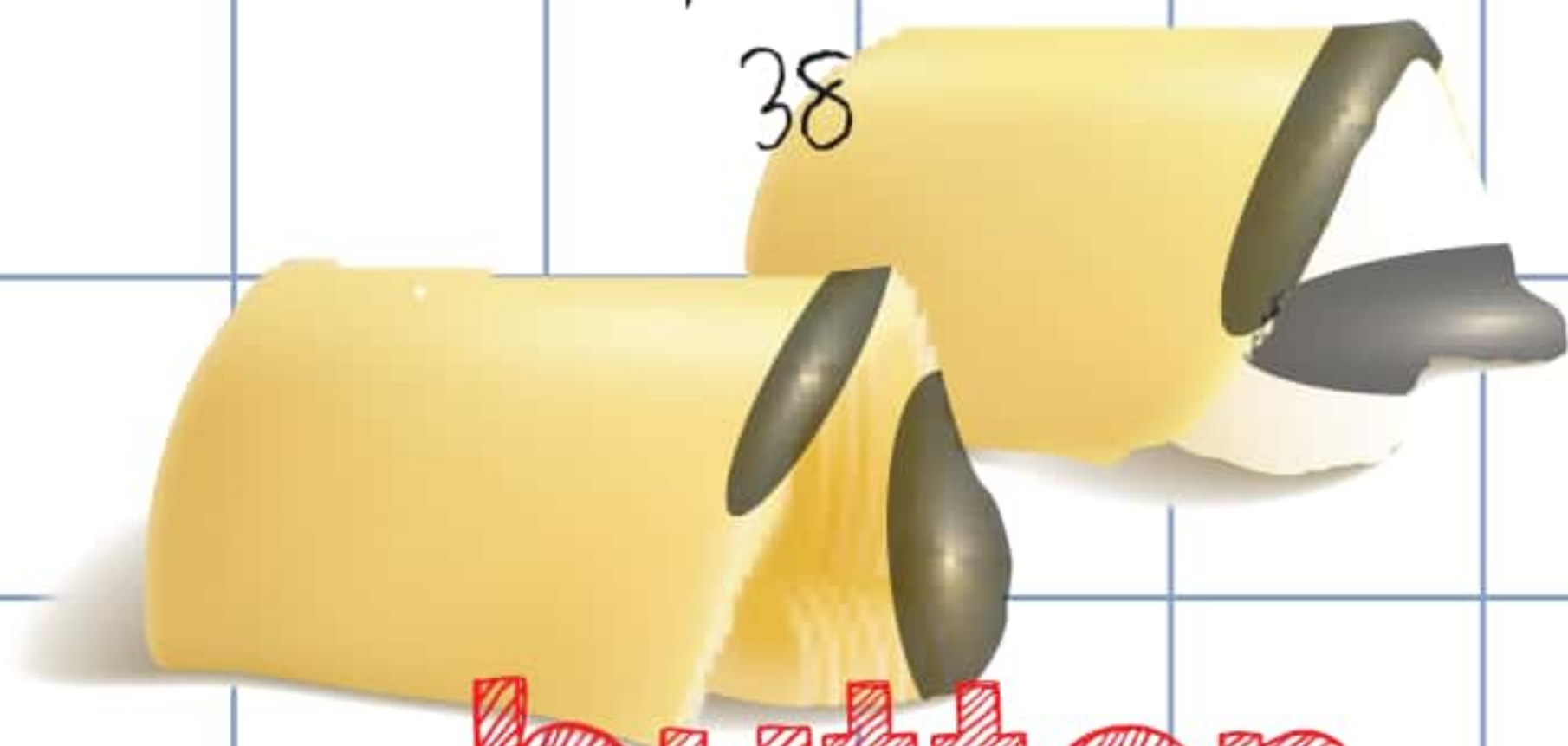

butter chicken maggi

Merawala Maggi - upgraded with Bhukkad Butter Kukkad
Ever heard of a better buttery combo?

36



half-fries half-rice

Can't decide what to order?

Welcome to the Bhukkad cocktail - Half-plate of fries and the other half of rice topped with Makhni Gravy & Cheese

Non-Veg 38

Veg 36

butter paneer sandwich

Our Fresh Malai Paneer in Makhni Gravy stuffed b/w breads & grilled until

buttery crisp

38

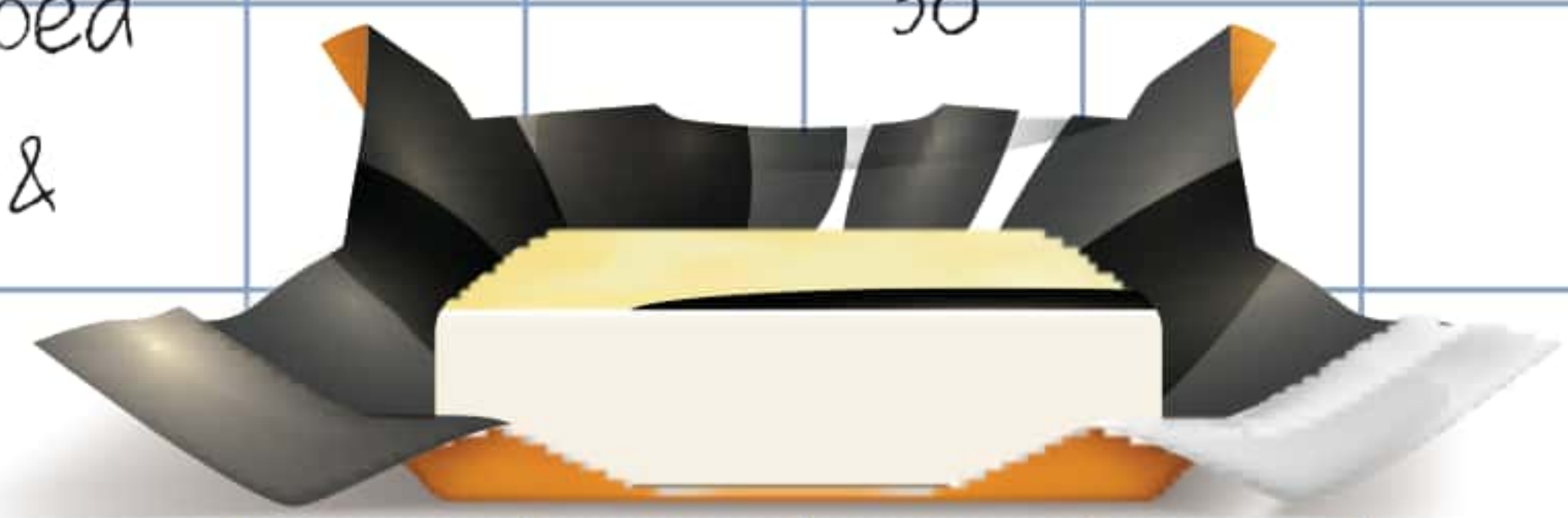

butter paneer maggi

Malai Paneer in Makhni Gravy + Merawala Maggi - a match made in our kitchen

34



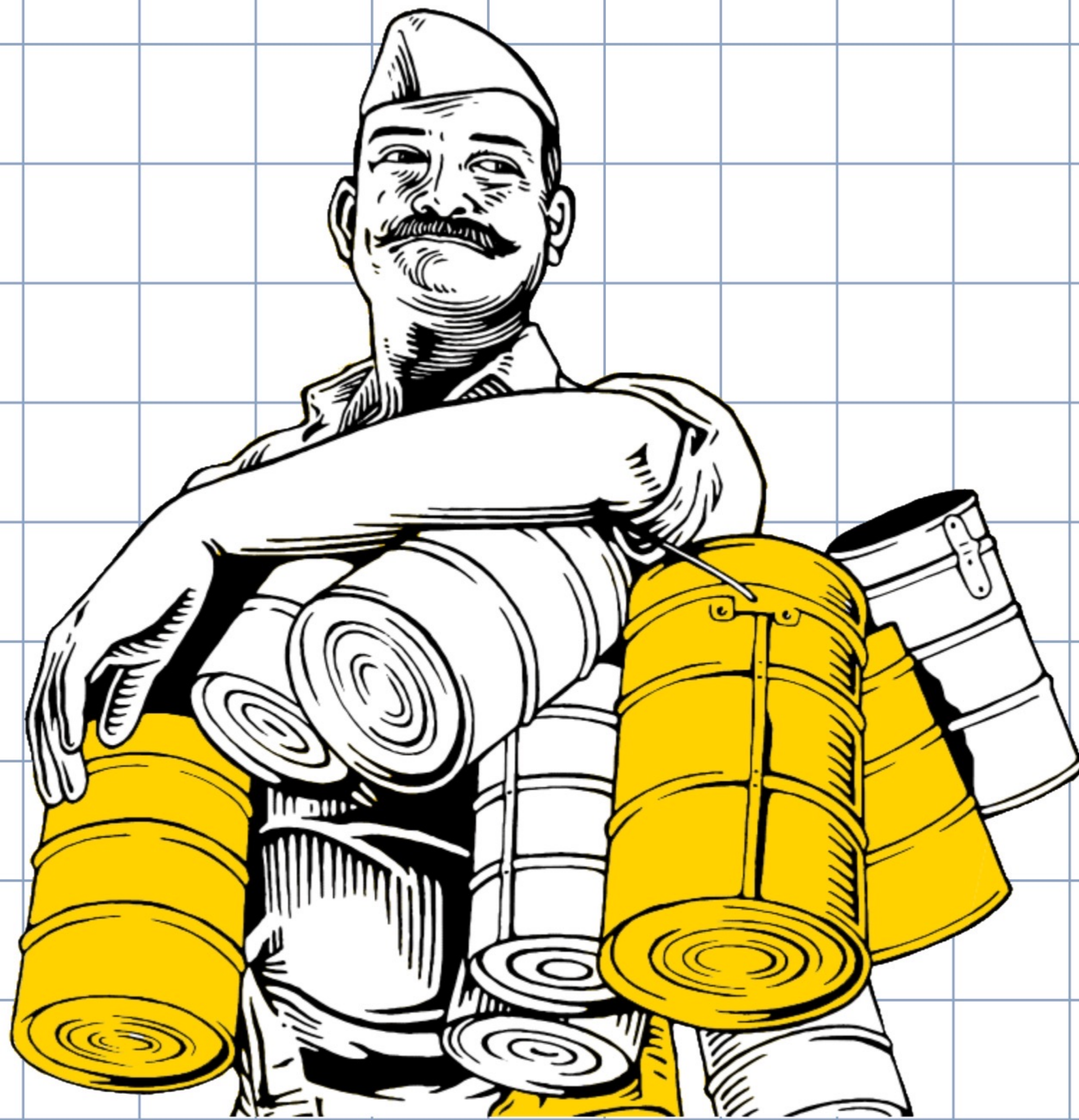

kebabs

try out our juicy and
succulent kebabs and
curries that will leave you
wanting more

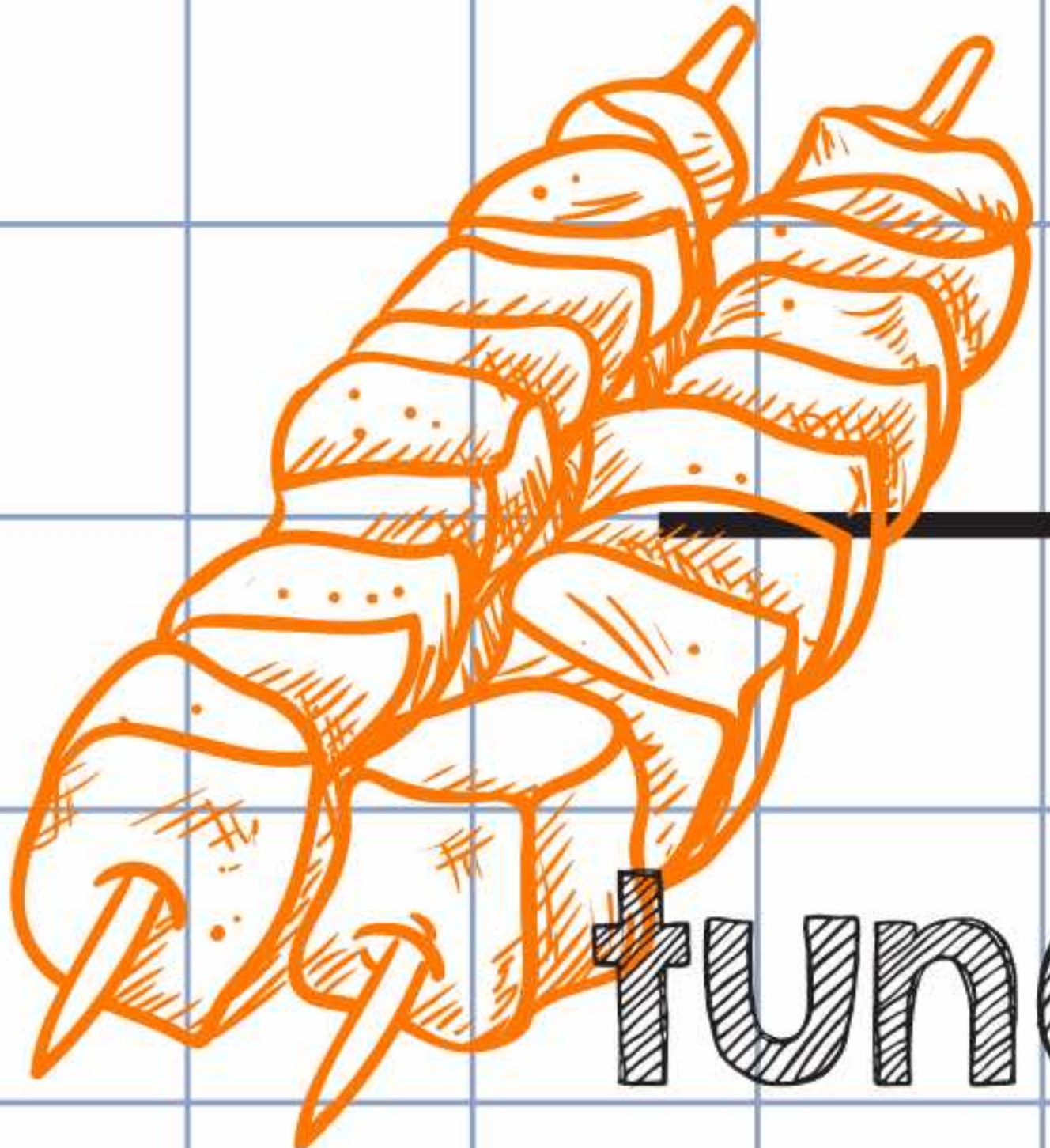

the **bhukkad** menu



tunde kebab

Famous Kebab from Lucknow - made with juicy, tender mutton & our secret homemade spices

48

chicken shami kebab

Minced Chicken & Chana Dal Kebab, spiced with our secret technique for a light texture

48

kalmi kebab

Also Known as tangdi Kebab, chicken drumsticks, marinated with spices & cooked in tandoor until moist & juicy

48

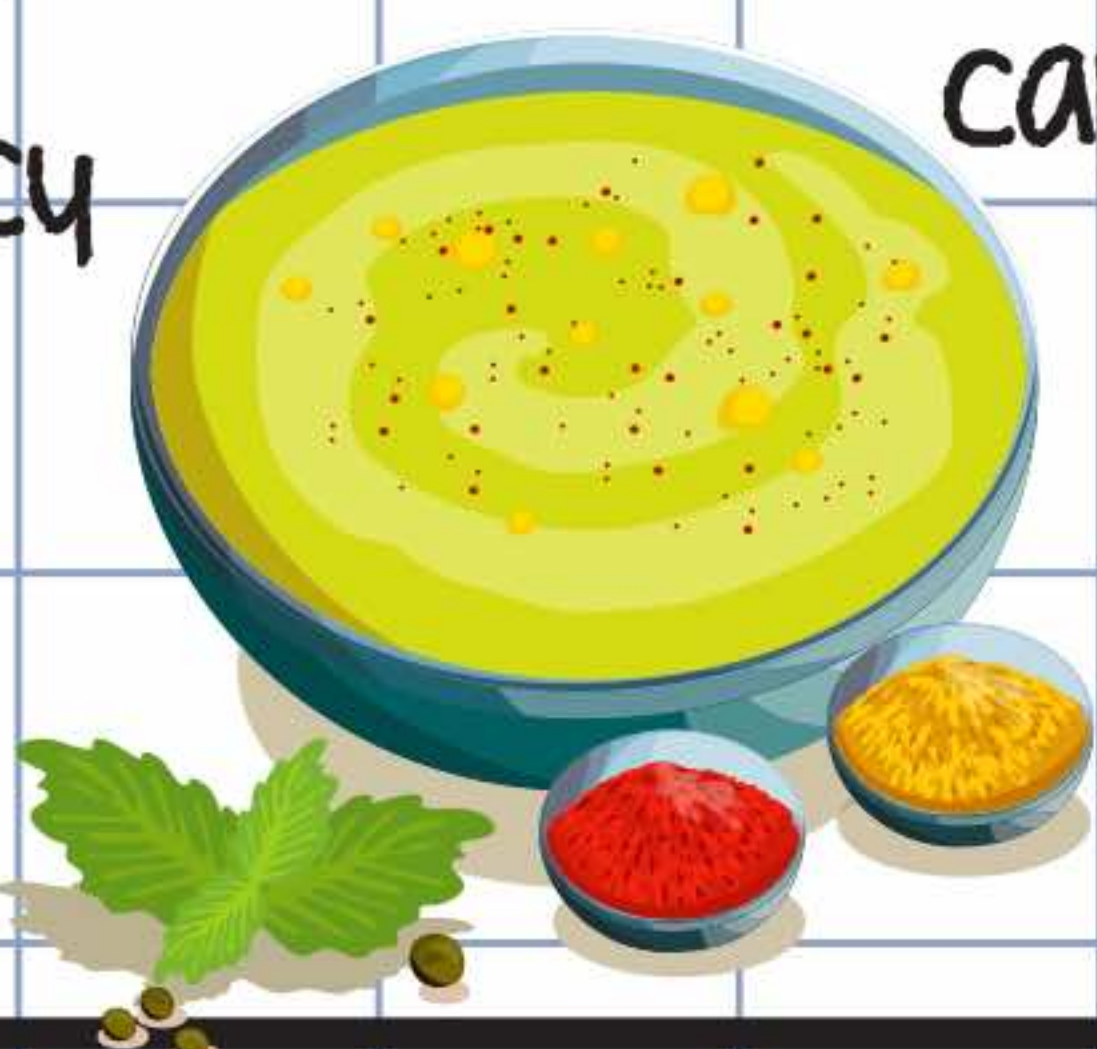

seekh kebab dippers

Minced & juicy chicken seekh kebabs served with our homemade mint chutney

48

chicken ghee roast

Street style Mangalorean chicken roasted in spices and ghee

48

paneer achari tikka

Cubes of Malai Paneer marinated in spicy, achari marinade & cooked with capsicums

44

murgh malai tikka

Succulent juicy chunks of chicken marinated with yoghurt & cream, brushed with butter

48

chapli kebab

Flattened minced mutton Kebab, spiced & fried, served with vinegar onions

48

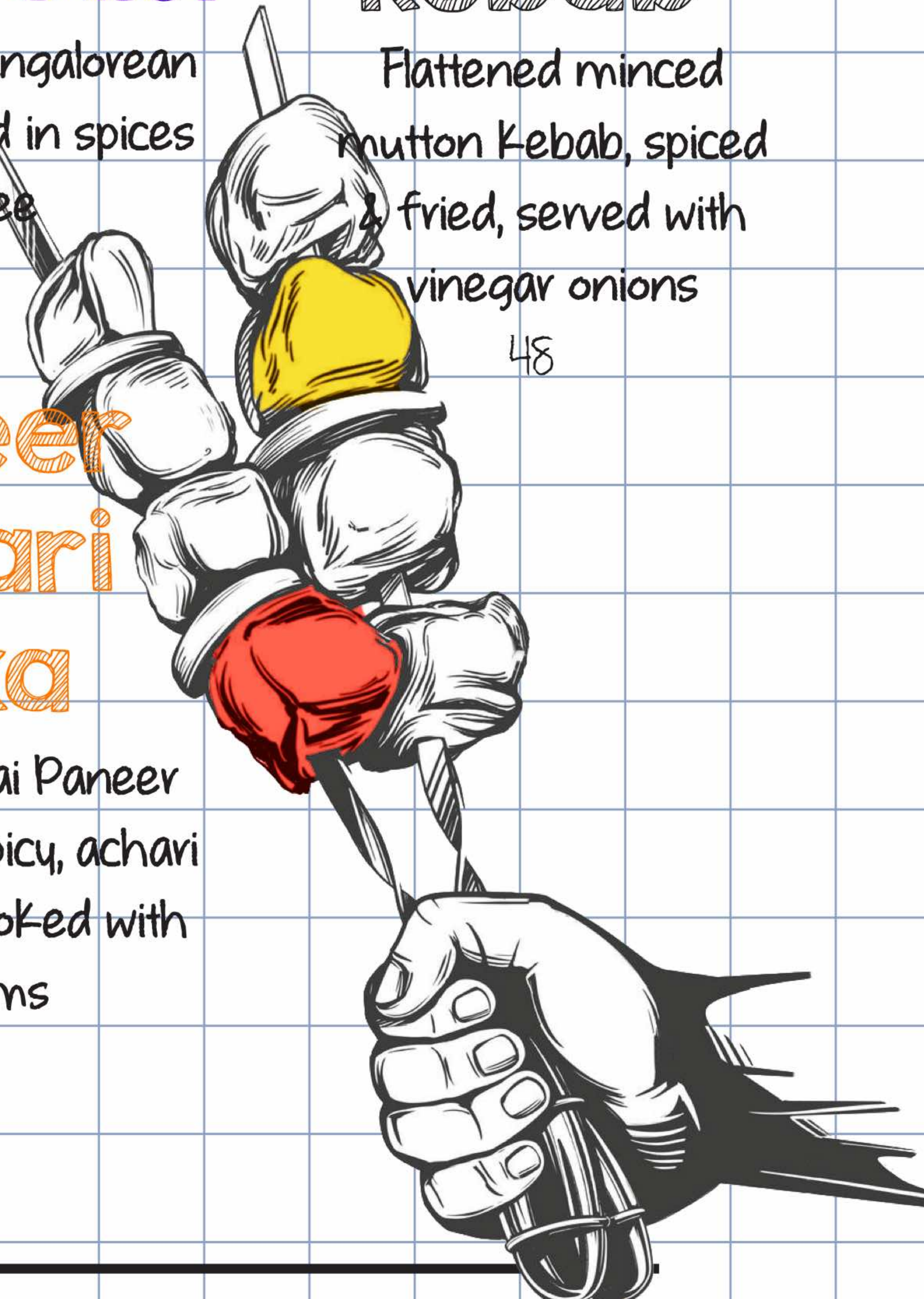

the **bhukkad** menu

the big bhukkad biryani

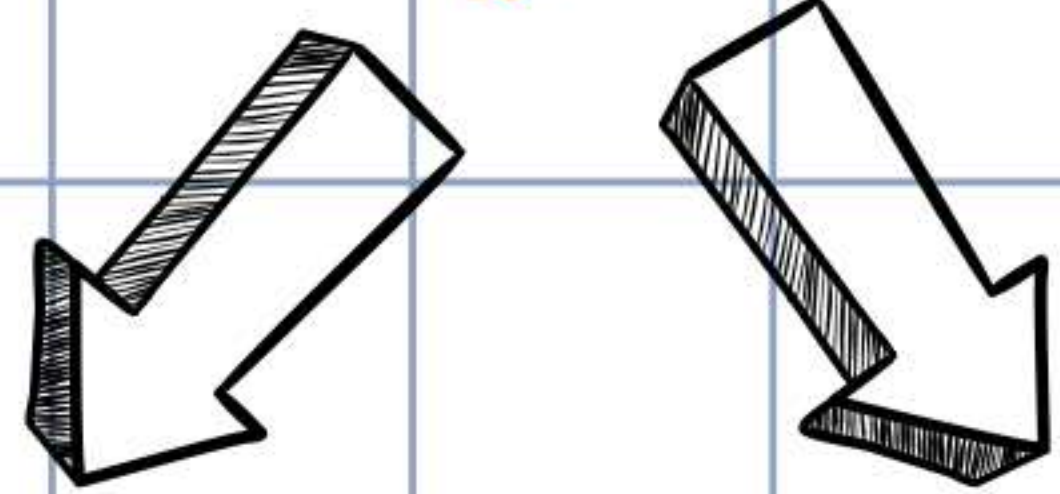

chicken

48

mutton

54

chur-chur kulcha

Crispy & Flaky on the
outside, soft and
buttery inside -
stuffed with our
secret filling

18

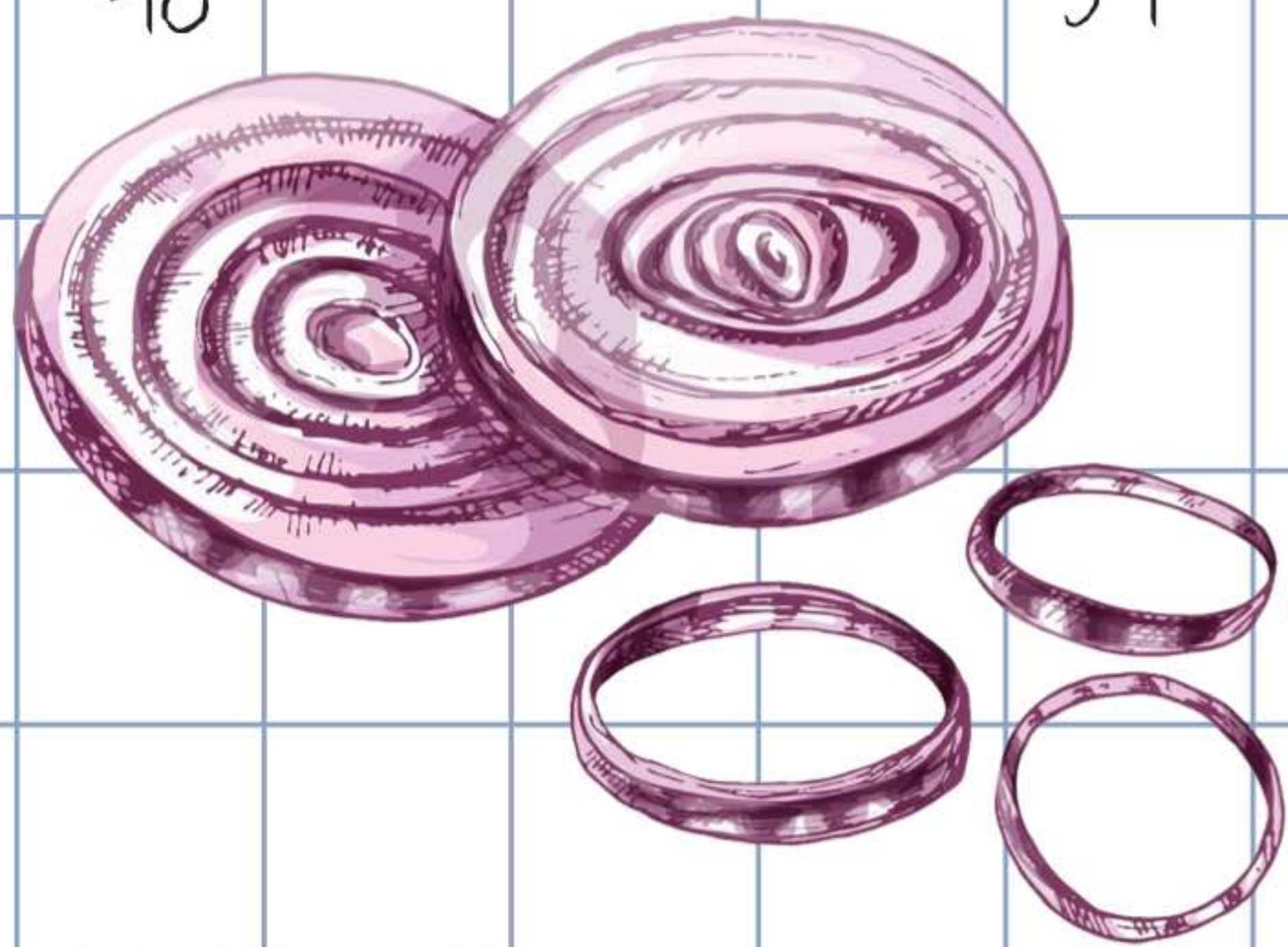

chicken dhansak

Parsi-style chicken curry
slow cooked in a gravy of
mixed lentils and herbs

44

bihari

champaran mutton

Famous spicy mutton
curry from Patna -
cooked in a clay pot in a
rich flavorful gravy

48

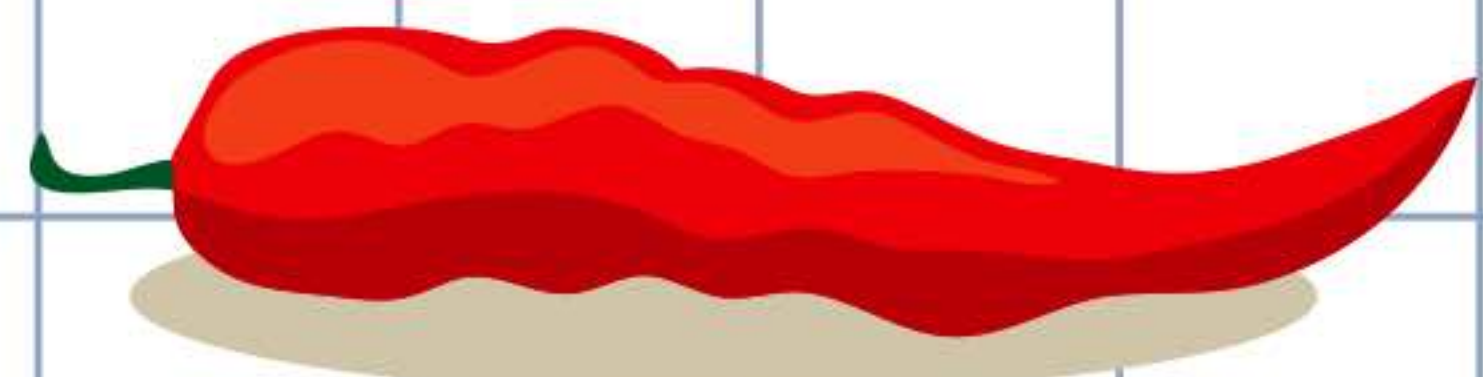

naan tacos

38



butter
chicken



butter
paneer



train rukne ke baad utrega kya?
gaali kay ko deta hai re?
bess kaunsi train hai ye?

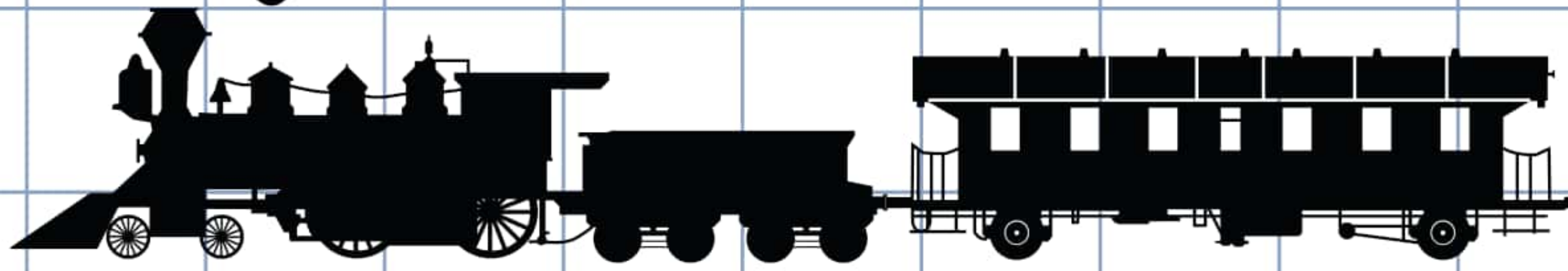

drinks

mandatory section for all the
binge eating you intend to do
- burp guaranteed!

thebhukkadstory



चाय chai

Whether you are in the mood for an underlining heat of the Adrak, or the sweet pleasure of Kesar Elaichi, or the perfectly balanced brew of homemade masalas, Chai is an emotion best understood when you take the first sip.

For Chai is Nostalgia.
For Chai is Pure Love.

There's nothing better than waking up to the smell of freshly brewed, roasty aromas & nutty fragrance of coffee - Whether you go videsi with frothy capuccinos or you crave that Beat-Wali gharelu cuppa, you're in for a soul-stirring treat.



coffee काफ़ी



दूध doodh

Its uncanny how we begin to love the things we used to hate as kids - Now we love to smack our tongues relishing the rich Pista flavours, lick the malai from our lips topped on the Kadhai doodh & thank the heavens above for this bliss.

Our Freak-Shakes could definitely replace your boyfriend - Because they are tall & handsome, sweet & generous & come bearing extremely interesting flavors of popcorn, rasmalai & brownie - Dig in & go फ़ se Freak.



फ़्रीक शेक्स freak shakes



ठंडा thanda

With all the incessant BhukKad-panti, it is only right that we pair thanda to help you with that dhakaar - Go back to your school days with our watermelon Kala Khatta or to your grandma's garden with amrud, sprinkled with Kaala namak & prem.

There are all sorts of love stories - The best ones happen when you dunk a fat & juicy gulab-jamun into ice-cream. Or smell the ghee from your halwa. Or lick the chashni off your fingers. These prem Kahanis are matches made in heaven.



मीठा meetha

the bhukkad menu

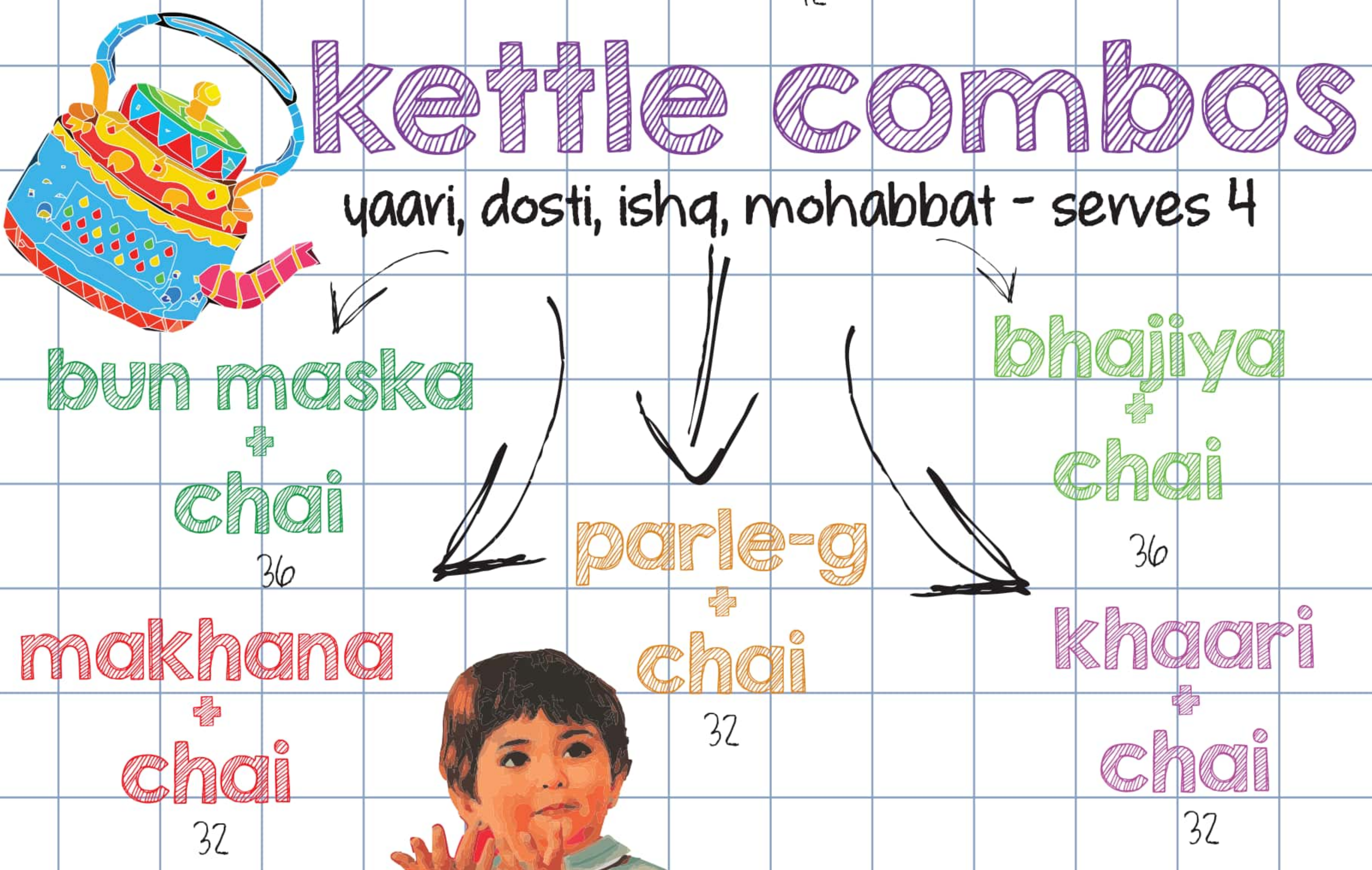

the bhukkad menu

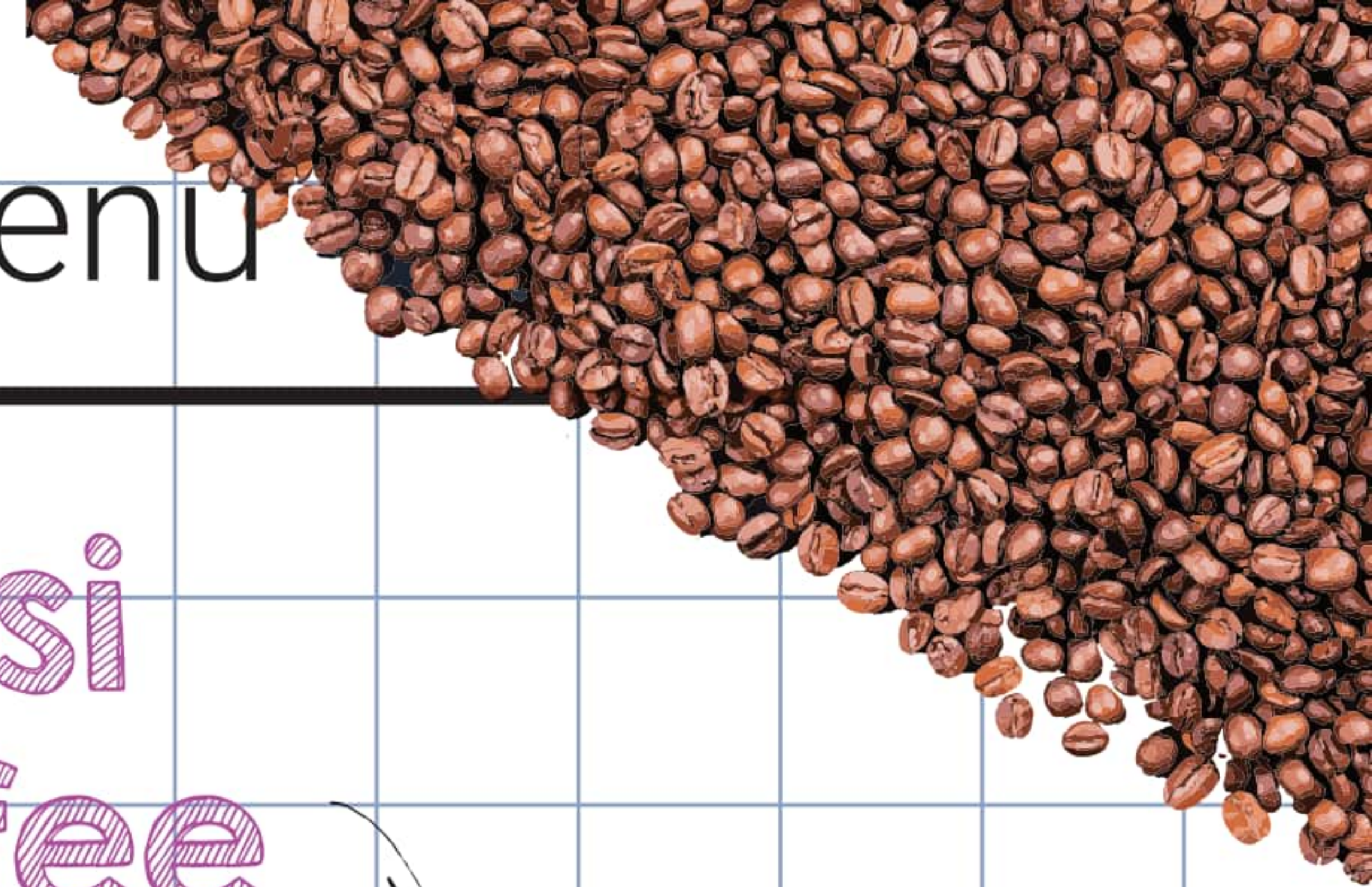

Carbury
DAIRY MILK
mastani
28

desi
coffee

beat wali
22

hot
chocolate
26

videsi
coffee

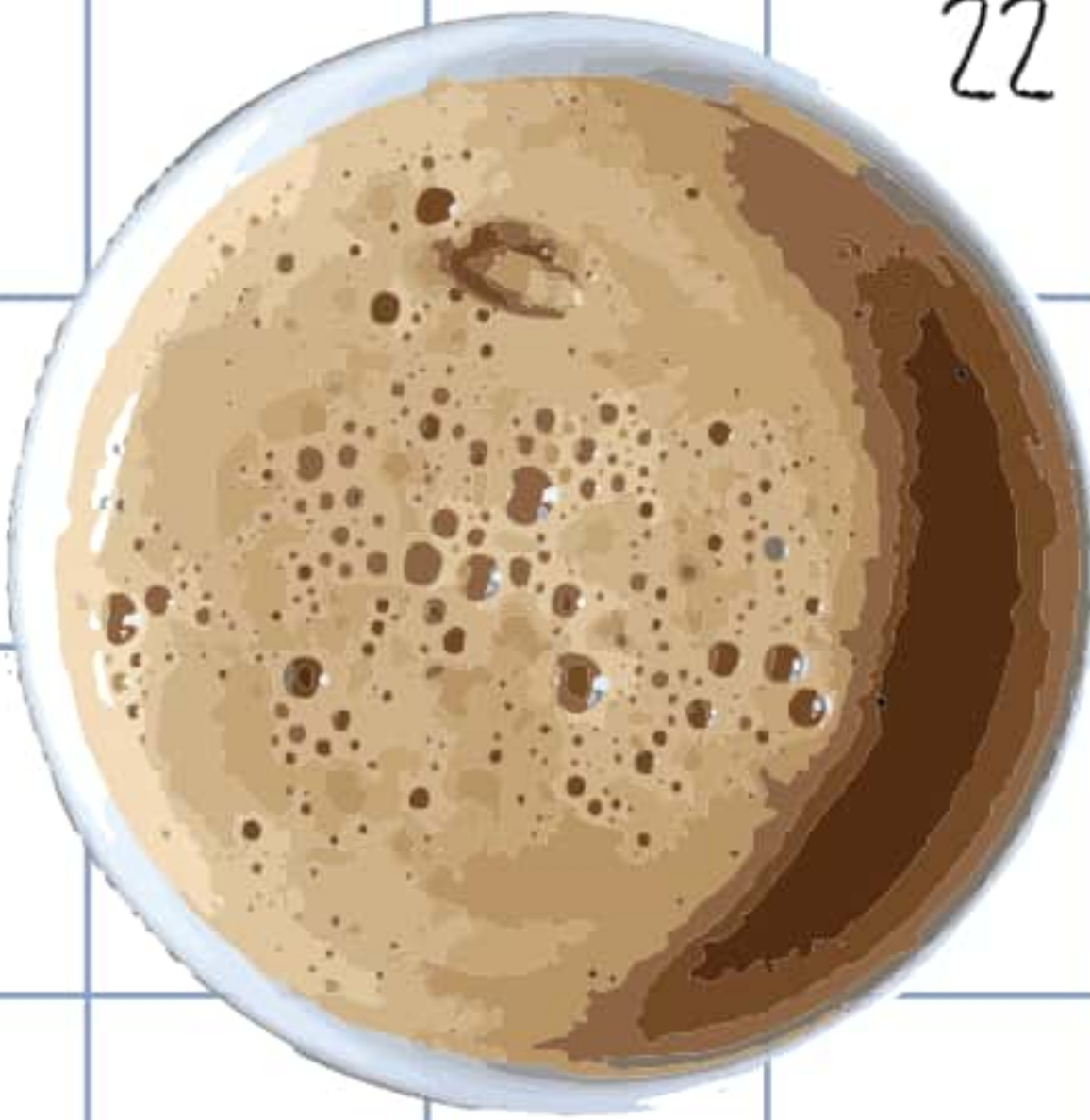

made
with
love

top it up

Caramel +4

Hazelnut +4

Vanilla +3

Chocolate +4

Ice-cream +6

Whipped
Cream +5

espresso 12

americano 18

latte 22

cappuccino 22

affogato 26



100%
FRESH

doodh

kesari
badaam
26

chocolate
26

pista
26



khajoori
26



the bhukkad menu



oreo
32

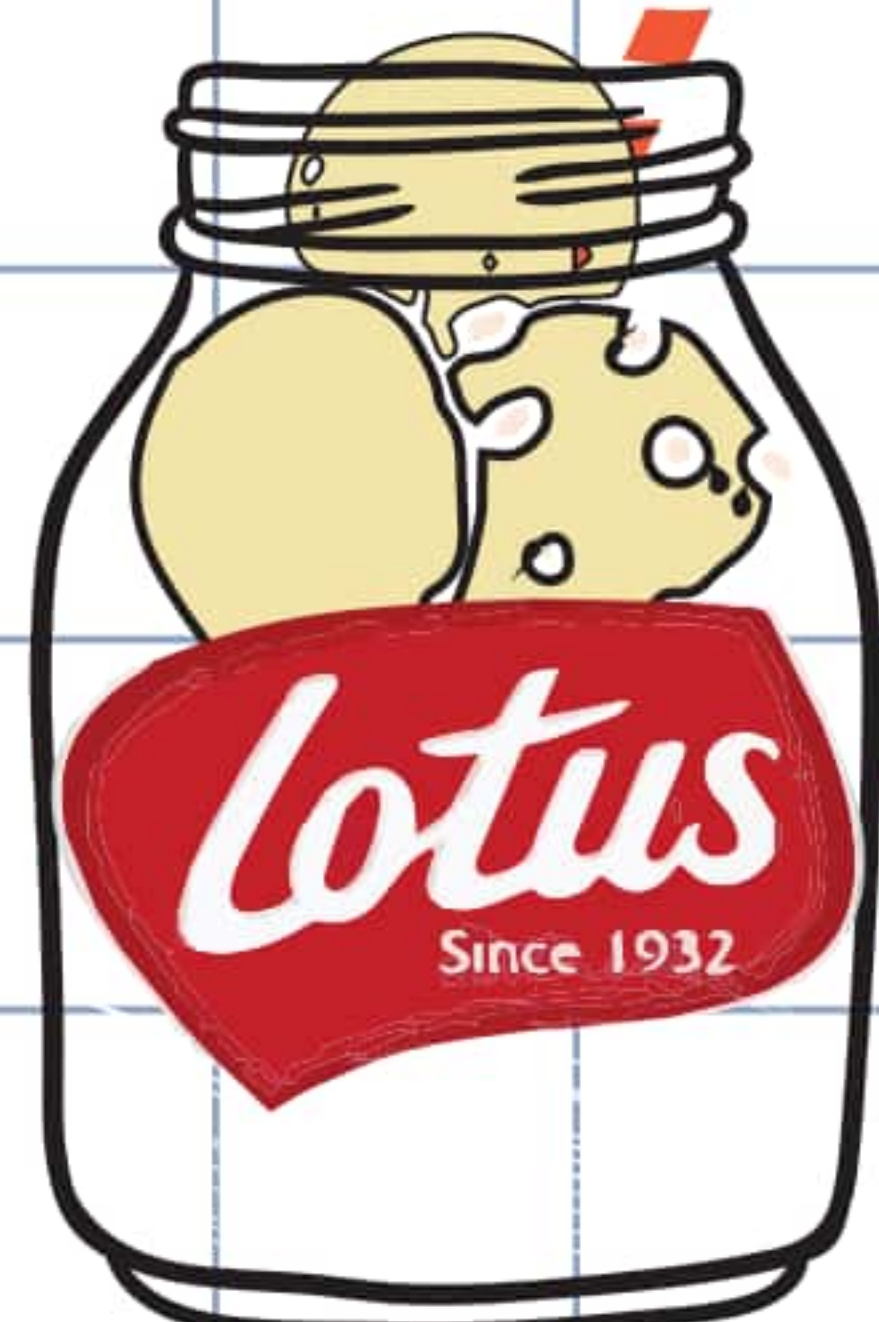

lotus
36



jalebi
36

rose
syrup



gulkand
36



kit-kat
34



ferrero
34



brownie
32



classic vanilla
32



banana
32

salted
caramel



bourbon
34



rasmalai
36

freak shakes

Loaded with decadence,
oozing with melty goodness,
topped with sweet pleasure
& totally instagram-worthy

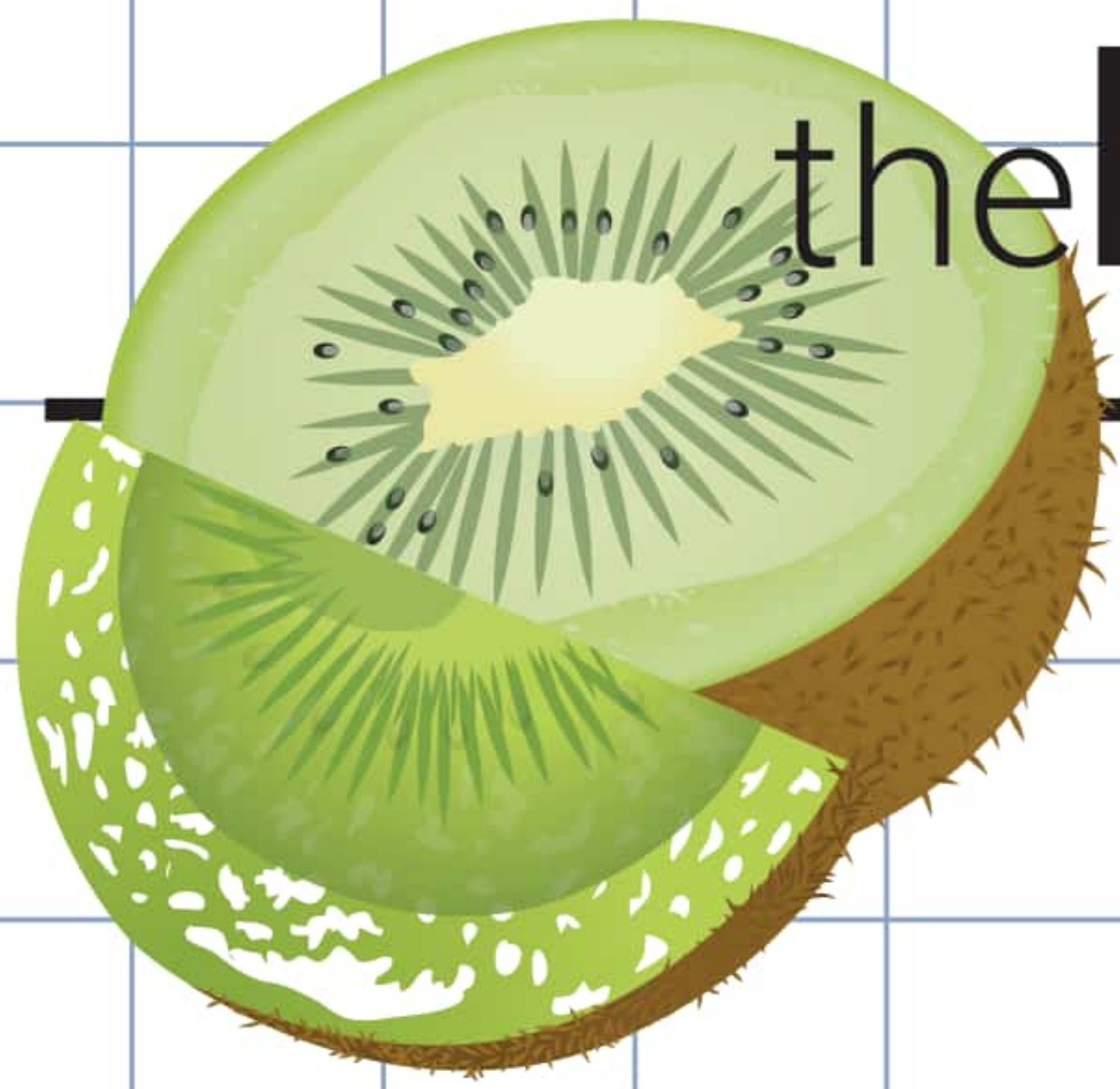

the bhukkad menu

kiwi
strawberry

32

peach
mango
banana

36

oats
banana
peanut
butter

36

choco
banana

28

smoothies

Thick, frothy and exotic

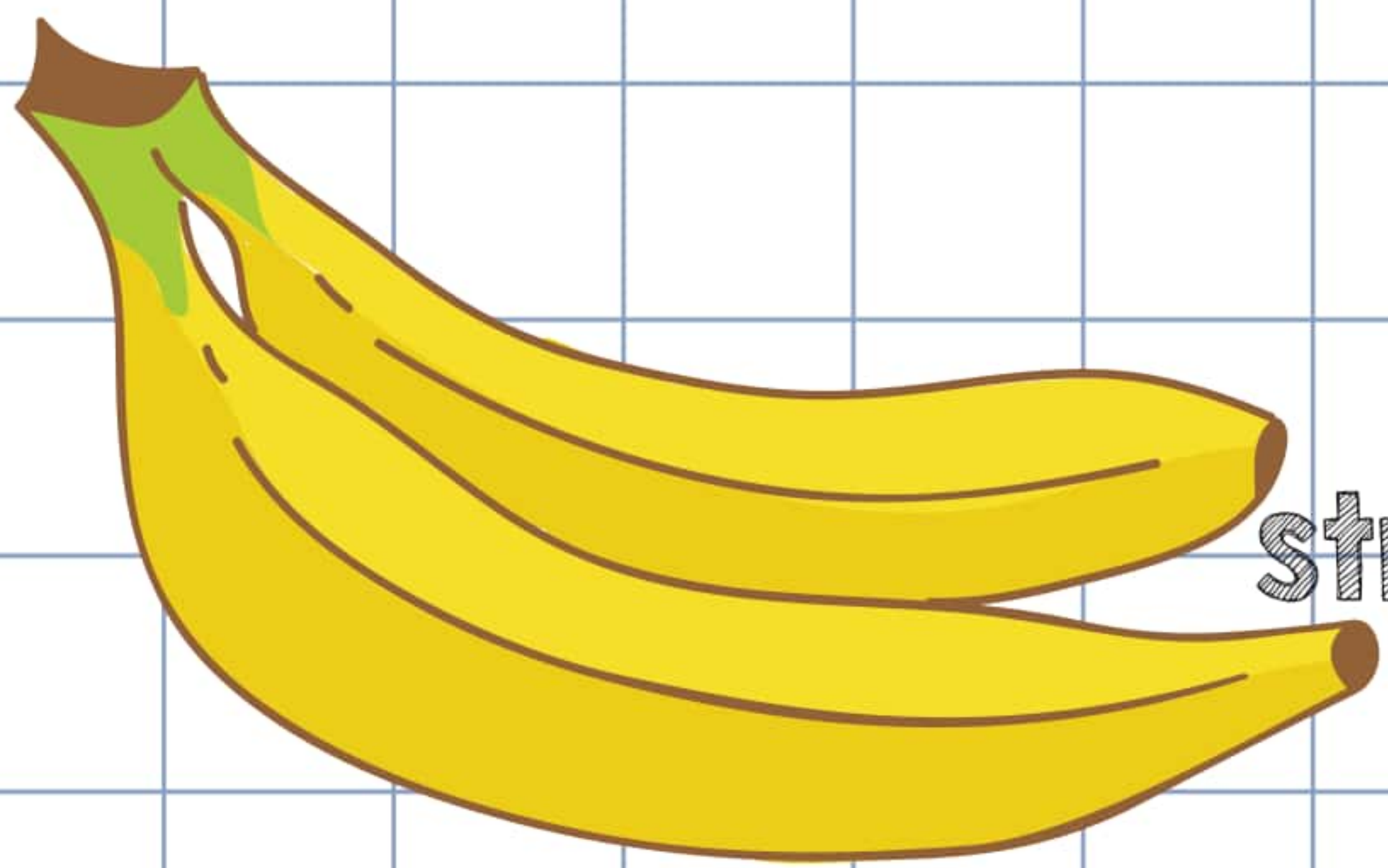

strawberry
banana

32

banana
peanut
butter

28

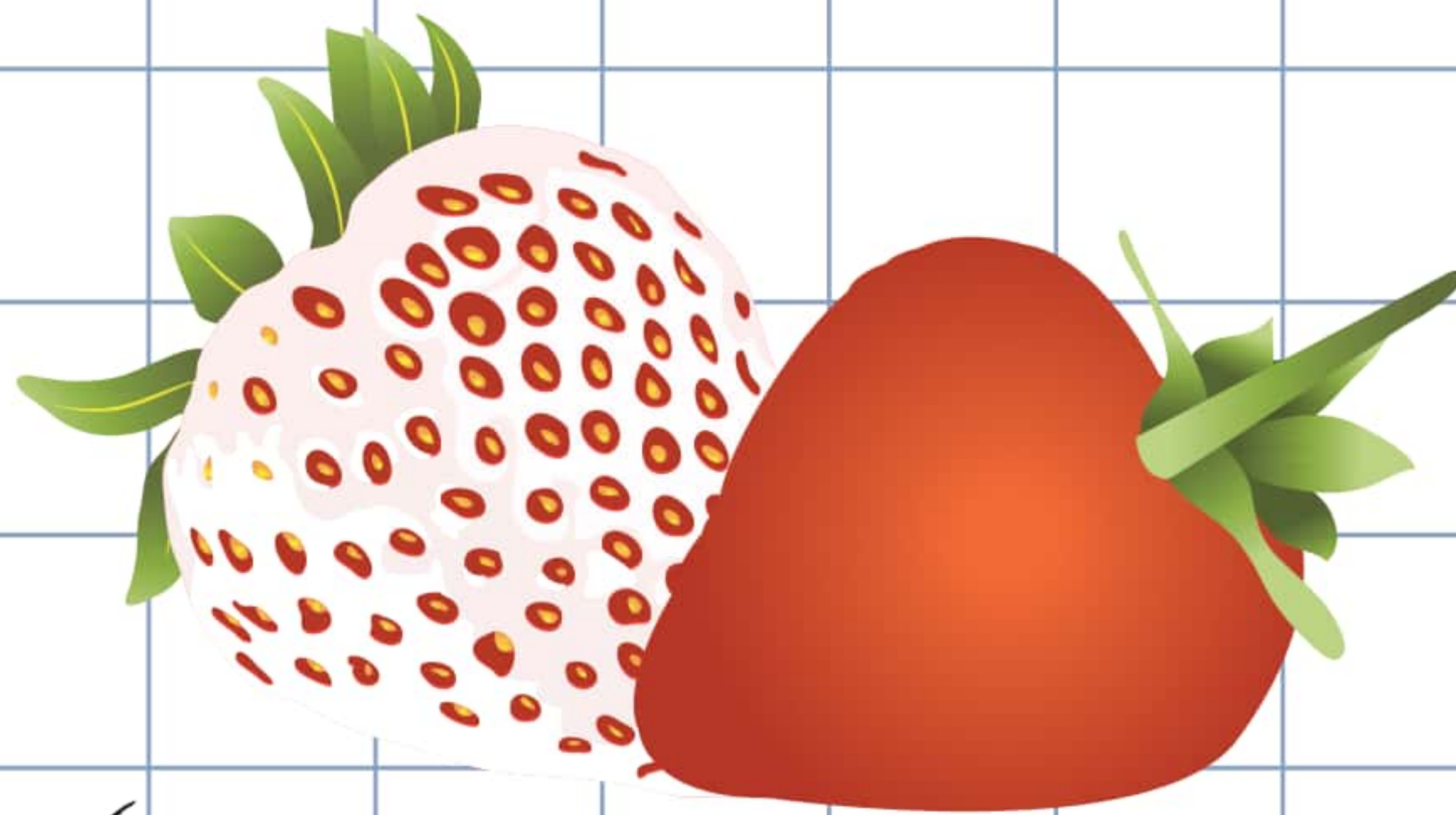

apna
classic

26

tropical
mango

30

very
berry

28

mojitos

Summery but good for all
seasons & reasons

pagal
pineapple

30

papa
don't
peach

28

mera melon
watermelon

28

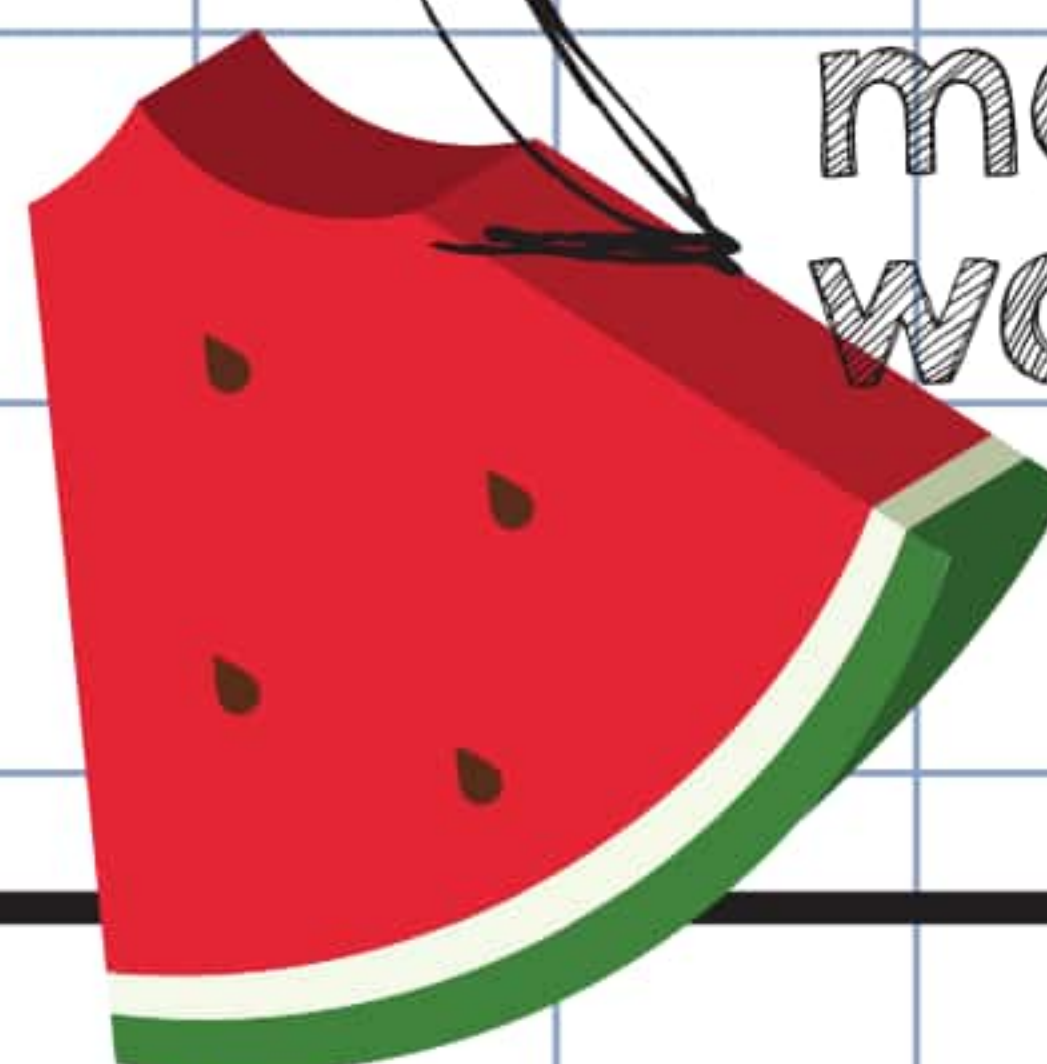
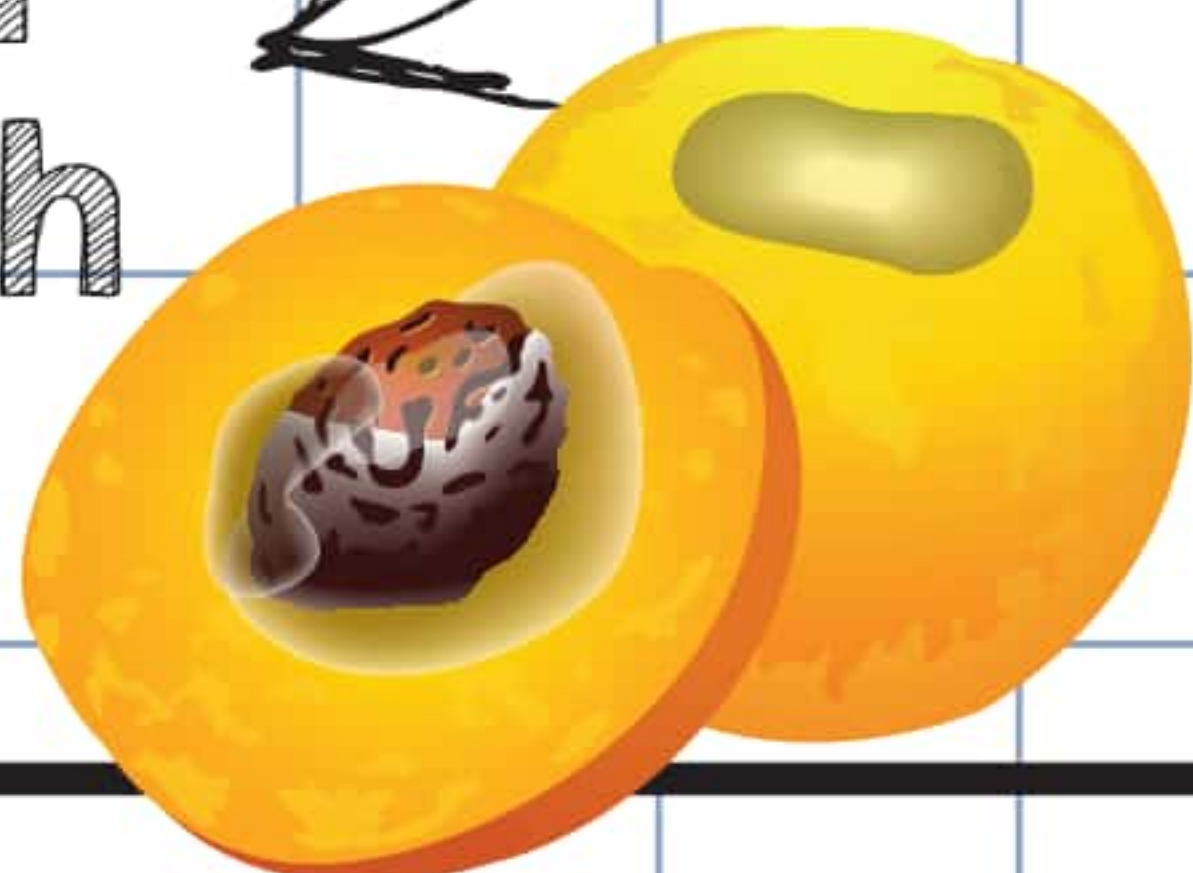

the bhukkad menu

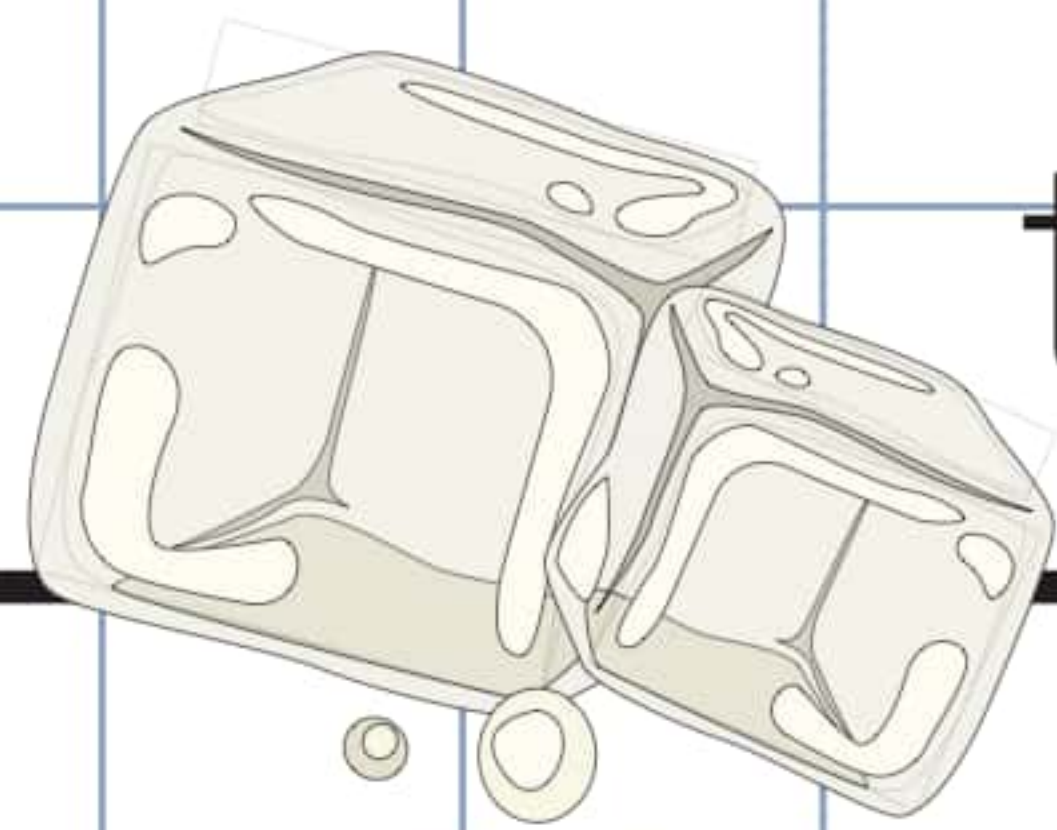

kokam
22

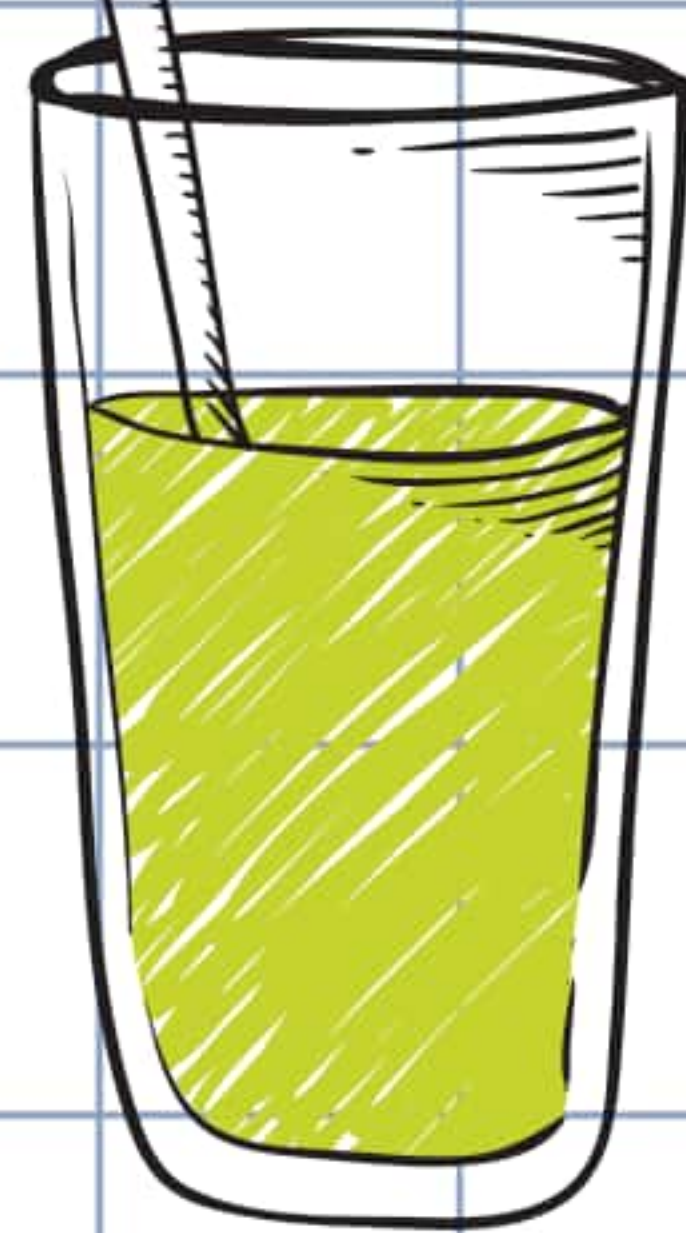

khus
22



aam
panna
26



shikanji
24



watermelon
kala
khatta
26

thanda

Desi enough for the loudest burp along with your bhukkad-ness.

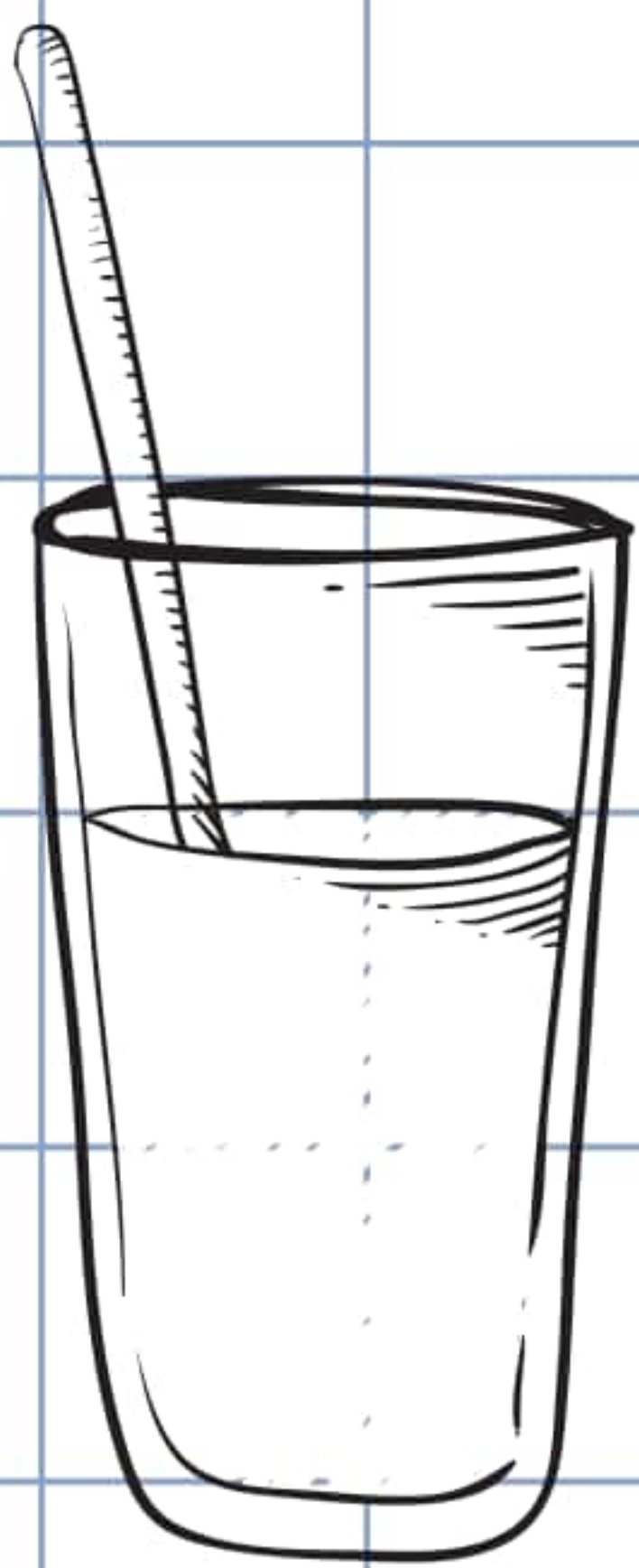

punjabi
lassi
28

sweet
salted
rose
strawberry
mango



coke float
24



barfeeli chai
22



amrud
26



indian
ocean
26



coke
8
sprite
8
fanta
8
water
4

pyaasa

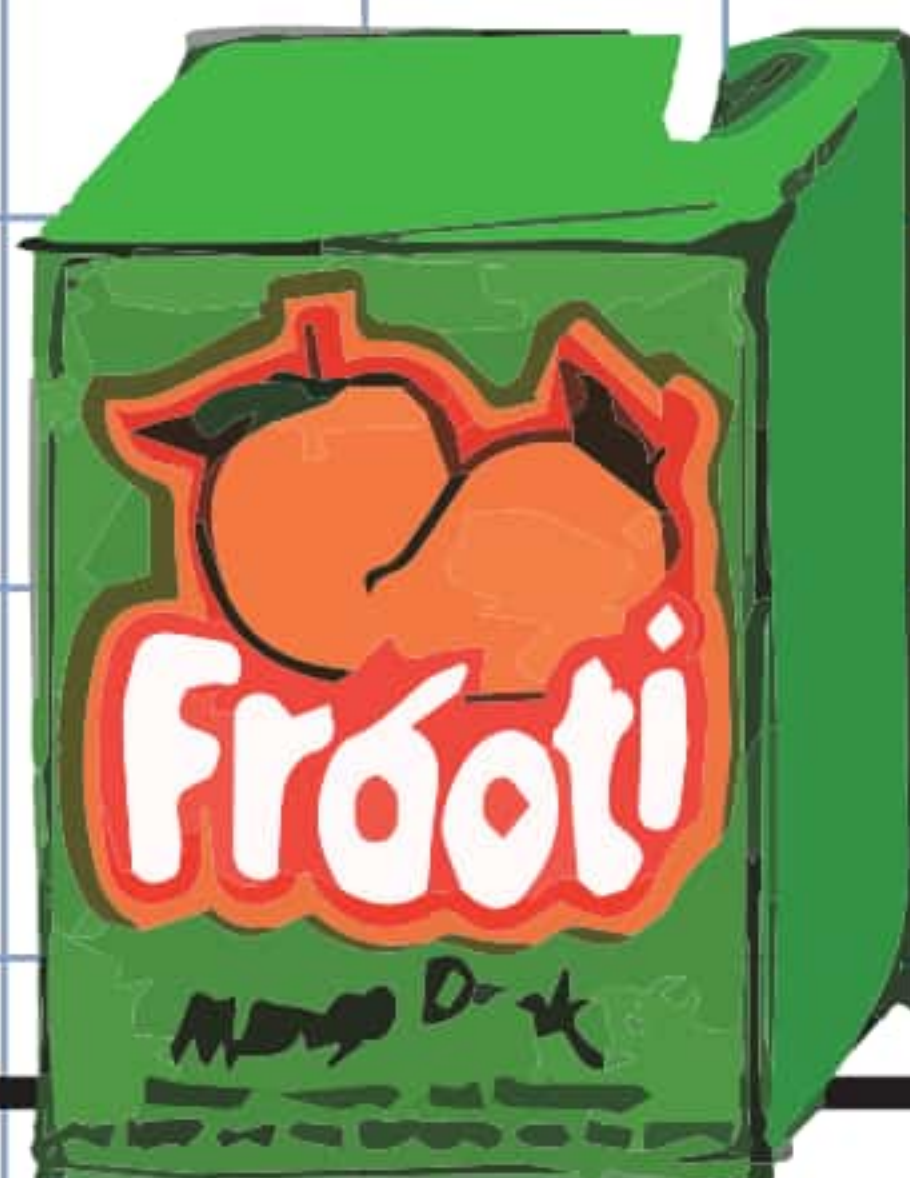

masala
thums-up
18
masala
limca
18
fresh juice
26



desserts

we don't allow any true Bhukkad
to leave without indulging in our
mouth-wateringly, gobsmacking
range of desserts

the bhukkad menu



jalebi
28

gulab
jamun
28



desi
meetha

malai
kulfi
22

rasmalai
28



paan
vanilla
28



gulkand
28

vanilla
22

gourmet
ice
cream



chocolate
24



gooey
fudgy
brownie
30

bhukkad
bonbon

sticky
toffee
28



molten
lotus
32

choco
lava
28



the**bhukkad**franchise

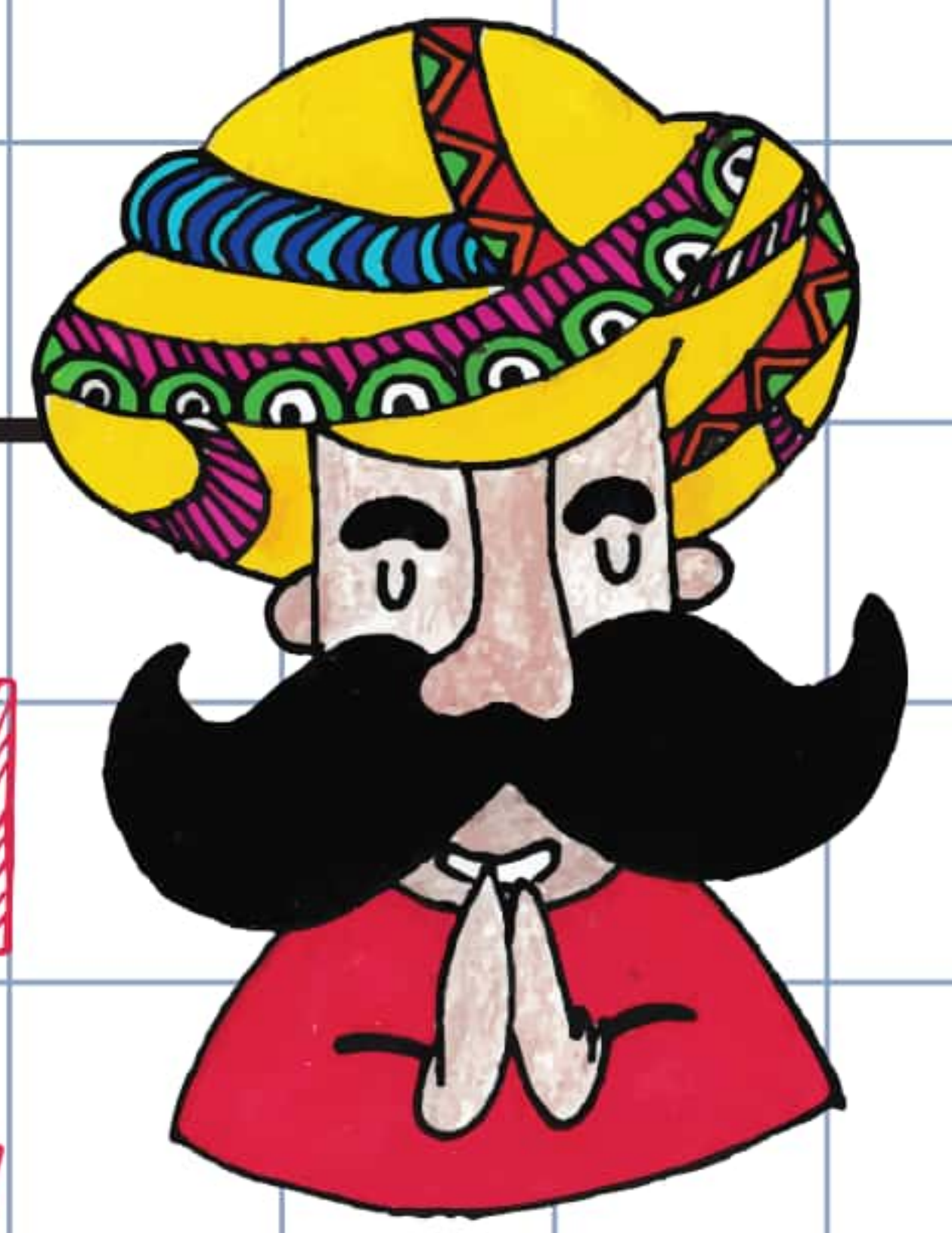

join the bhukkad
franchise family

franchise@thebhukkadcafe.com



[@thebhukkadcafe](https://www.instagram.com/thebhukkadcafe)



[The Bhukkad Cafe](https://www.facebook.com/The Bhukkad Cafe)



[The Bhukkad Cafe](https://www.linkedin.com/company/The Bhukkad Cafe)



[@thebhukkadcafe](https://www.tiktok.com/@thebhukkadcafe)



[The Bhukkad Cafe](https://www.zomato.com/The Bhukkad Cafe)



[The Bhukkad Cafe](https://www.ow.com/The Bhukkad Cafe)

